



**TENDER FOR
REPLACEMENT OF VIDEO SHOW RELAY SYSTEMS
WITH MAINTENANCE SERVICES AT SCHOOL OF
THE ARTS, SINGAPORE**

Name of Tenderer : _____

Closing Date/Time : **19 March 2025 at 1400 hours**

Submit To : **Tender Submission Box 3
Office Of Procurement
School Of The Arts, Singapore
1 Zubir Said Drive
Administration Office #05-01
Singapore 227968**

TABLE OF CONTENTS

		<u>PAGE</u>
SCHEDULE 1.	INSTRUCTION TO TENDERERS	IT/1 to IT/11
SCHEDULE 2.	FORM OF TENDER	FOT/1 to FOT/3
SCHEDULE 3.	SCHEDULE OF PRICE	SOP/1 to SOP/8
ANNEX A.	CONDITIONS OF CONTRACT	COC/1 to COC/18
ANNEX B.	SELECTION CRITERIA	SC/1
ANNEX C.	TECHNICAL REQUIREMENTS	TR/1 to TR/28
ANNEX D.	SCOPE OF WORKS	SOW/1 to SOW/5
ANNEX E.	STATEMENT OF COMPLIANCE	SOC/1 to SOC/4
ANNEX F.	CONSORTIUM DECLARATION	CD/1 to CD/2
APPENDIX i.	VIDEO SHOW RELAY SYSTEM EQUIPMENT LAYOUT PLAN	Appx i/ 1 to Appx i/ 13
APPENDIX ii.	VIDEO SHOW RELAY SYSTEM SIGNAL BLOCK DIAGRAM	Appx ii/ 1 to Appx ii/ 3
APPENDIX iii.	TECHNICAL SPECIFICATION FOR STAGE MANAGER CONTROL DESK	Appx iii/ 1 to Appx iii/ 4

Our Ref : **SAS/OP/2024/013/T**

14 February 2025

Dear Sir/Mdm,

INVITATION TO TENDER (ITT) FOR REPLACEMENT OF VIDEO SHOW RELAY SYSTEMS WITH MAINTENANCE SERVICES AT SCHOOL OF THE ARTS, SINGAPORE (ITT REFERENCE NO: SAS/OP/2024/013/T)

1. **Singapore Arts School Ltd. (SAS)**, the company that manages the **School of the Arts, Singapore (SOTA)**, governed by the Ministry of Culture, Community and Youth (MCCY), invites proposals for the **Tender for the Replacement of Video Show Relay Systems with Maintenance Services** at **1 Zubir Said Drive, Singapore 227968** as described in the attached documents.
2. You must submit your proposal and any accompanying information to our **Tender Submission Box 3** at 1 Zubir Said Drive, Administration Office #05-01, Singapore 227968 by **19 March 2025, 1400 hours Singapore Time**. All late and/or incomplete submissions will be disqualified.
3. The documents enclosed in this ITT includes:
 - (a) Schedule 1 : Instruction to Tenderers
 - (b) Schedule 2 : Form of Tender
 - (c) Schedule 3 : Schedule of Price
 - (d) Annex A : Conditions of Contract
 - (e) Annex B : Selection Criteria
 - (f) Annex C : Technical Requirements
 - (g) Annex D : Scope of Works
 - (h) Annex E : Statement of Compliance
 - (i) Annex F : Consortium Declaration
 - (j) Appendix i : Video Show Relay System Equipment Layout Plan
 - (k) Appendix ii : Video Show Relay System Signal Block Diagram
 - (l) Appendix iii : Technical specification for Stage Manager Control Desk
4. The Invitation to Tender must be submitted by the Tenderer's authorised representatives.
5. The **Online Tender Briefing** for the tender requirements and documents submission will be held on **20 February 2025, 1030 hours Singapore Time** via Teams video conferencing.

6. There will be a **mandatory Site-show Session**, and tenderers may choose to attend on either **22 February 2025 (Saturday)** or **8 March 2025 (Saturday)**, from **0900 hours Singapore Time**, at 1 Zubir Said Drive, Level 2 Security Counter. This session is intended to help tenderers to understand the requirement specifications within our school compound. Tenderers are strongly encouraged to attend the earlier session.
7. Attendance is **mandatory** for both the **Online Tender Briefing** and **one of the Site-show Sessions** on any of the dates specified in point 6.
8. Tenderers must fill in the registration form [here](https://forms.gle/v3qaSgeZVAtn97Bd9) (<https://forms.gle/v3qaSgeZVAtn97Bd9>) to confirm their attendances for the **Online Tender Briefing** and **Site-show Session** no later than **19 February 2025, 1200 hours Singapore Time**.
9. All enquiries and clarifications regarding this Invitation to Tender must be made in writing and directed to:
 - (a) Tender Matters : Ms Jacqueline Tan, Direct line: 6342 5821 &
Email : procurement@sota.edu.sg
 - (b) Requirement Specifications : Ms Jennifer Tan
Email : jennifer.tan@sota.edu.sg
10. No oral representation must be binding on SAS or construed as varying or adding to any part of this Invitation to Tender.
11. SAS accepts original Tender Documents Submission and strictly without any alteration to the content and format.
12. Only shortlisted Tenderers will be invited for a presentation.

Yours sincerely

(No Signature Required)

Jacqueline Tan,

SENIOR EXECUTIVE, OFFICE OF PROCUREMENT for CHIEF EXECUTIVE OFFICER
SINGAPORE ARTS SCHOOL LTD

Schedule 1 :
INSTRUCTION TO TENDERERS

**TENDER FOR THE
REPLACEMENT OF VIDEO SHOW RELAY SYSTEMS WITH MAINTENANCE SERVICES AT
SCHOOL OF THE ARTS, SINGAPORE**

INSTRUCTION TO TENDERERS

1. The Tender Submission **MUST** comprise the following Tender documents;-
 - a) Schedules 1, 2 and 3
 - b) Annexes A, B, C, D, E and F (if applicable for Consortium)
 - c) Appendix i, ii and iii
 - d) Company Profile
 - e) Relevant Certification(s)/Letter, Distributor Certificate/ Letter, Training Certificate(s), Letter of Authorisation
 - f) Tender Proposal includes:
 - I. Product Brochures with Technical Specifications of the Proposed Brand and Model
 - II. Detailed installation plan includes cabling works
 - g) Client Track Records for past three (3) years
 - h) Two (2) most recent Audited Financial Statements or Latest Statement of Accounts
2. Tenderers must submit **2 full sets** of Tender documents in hardcopy. One set is to be marked "Original" and the other marked "Duplicate" and endorsed with **company stamp and authorised signatory on every page.**
3. Tender documents must be submitted to the "**TENDER SUBMISSION BOX 3**" located at :

School of the Arts, Singapore
1 Zubir Said Drive Administration Office #05-01
Singapore 227968

by:

19 March 2025 (1400 hours) in sealed envelope(s) with the following marked :

"TO: OFFICE OF PROCUREMENT

**TENDER FOR THE REPLACEMENT OF VIDEO SHOW RELAY SYSTEMS WITH
MAINTENANCE SERVICES AT SCHOOL OF THE ARTS, SINGAPORE**

TENDER REFERENCE: SAS/OP/2024/013/T"

4. All Tender Documents appended with conditions other than those set out herein and/or at variance with thereto shall be invalidated.
5. Any items which the Tenderer considers to have no value must be marked with dashes or other suitable marks placed against them in the cash columns. Any items not priced and without dashes or other suitable marks must be deemed to be of no value.
6. Incomplete tender submission or submission of which are found not meeting the full requirements as stated in the Annexes herein will not be considered.
7. Any doubt as to the meaning of any part of these Tender Documents may be clarified with SAS's representative. SAS is hereinafter known as the "Company".

8. Tenderers shall note that the award of the contract may not necessarily be to the lowest quotes of any proposal and any claims for expenses incurred in the preparation of this Tender will not be entertained. The Company may choose to award the Tender in whole or in parts.
9. All Tenders submitted must be deemed to be valid for a period of ninety (90) days from the date of submission thereof.
10. Before the submission of their Tenders, Tenderers must attend the online Tender Briefing and one of the Site-show Sessions in to acquaint themselves thoroughly with the requirements, conditions and all aspects of the tender which may affect the works under this contract. Any unforeseen difficulties and works for which provision has not been made in the Tender price quoted will under no circumstance relieve the Tenderers from the full performance of this Contract.
11. Tenderers are also reminded that the Conditions of Contract (Annex A), Technical Requirements (Annex C), Scope of Works (Annex D) and Statement of Compliance (Annex E) attached herein must be strictly adhered to unless specified that SAS accepts alternative proposed.
12. A "NIL" return of the Tender submission on any required Schedules will not be accepted.
13. The Contract Sum submitted must exclude any Goods and Services Tax (hereinafter referred to as GST) under the Goods and Services Tax Act Singapore.

CONFIDENTIAL

PARTICULARS OF TENDERER

All sections are mandatory to fill up

Note : From IT/3 onwards, if the space provided is insufficient, please continue on an extension page setting out the required data in a similar manner.

1 REGISTERED BUSINESS NAME AND ADDRESS OF FIRM/COMPANY

a) Type of firm (✓ tick one of the appropriate box only)

Sole Proprietorship Partnership
Private Company Public Listed Company
Others (Please specify) : _____

b) Is the tender submitted by a Consortium? (✓ tick one of the appropriate box only)

Yes No

For Consortium, the Lead Organisation is required to fill up item 1c) to item 1m), item 2 and item 3 and all members of the Consortium are required to fill up Annex F (Consortium Declaration).

- c) Full Business Name :
- d) Registered Address :
- e) Correspondence Address :
- f) Telephone Number :
- g) Fax Number :
- h) GST Registration : Yes / No (please circle one)
- i) GST Registration No. :
- j) Date and Number of Business Registration :
- k) Date of Incorporation :
- l) Form of Business :
- m) Name (as in NRIC/FIN) and Designation of Authorised Representative :

2 **CAPITAL**

a) If Partnership to state the capital set aside for business

Capital Set Aside :

b) If Limited Company, to state the authorised and paid-up capital

Paid-up Capital :

c) Extracted from two (2) most recent Audited Financial Statements or Latest Statement of Accounts

- i. Company with an annual revenue less than S\$5 million, to submit company endorsed Statement of Account.
- ii. Company with an annual revenue S\$5 million or more, to submit Audited Financial Statement

Latest Audited Financial Statements/ Statements of Account

Please submit Audited Financial Statements or Statements of Account

Annual Report Year and Descriptions	Financial Year 20__	Financial Year 20__
Paid-Up Capital (S\$)		
Current Assets (S\$)		
Current Liabilities (S\$)		
Non-Current Assets (S\$)		
Non-Current Liabilities (S\$)		
Total Revenue (S\$)		
Net Profit / Loss (S\$)		

**3 REGISTRATION WITH GOVERNMENT SUPPLIER REGISTRATION (GSR)-
CONTRACTOR REGISTRATION SYSTEM INFORMATION**

GSR Head (with date of expiry if applicable)	Head Title	Financial Category / Grade

**4 DEBARMENT/SUSPENSION/PROHIBITION (OR ANY FORM OF EXCLUSION OR
EQUIVALENT, IF ANY)**

Name of Authority/ Regulatory Body or Equivalent	Reasons for Debarment /Suspension/Prohibition or any form of exclusion or equivalent, if any	Effective Date of Debarment/ Suspension/Prohibition or any form of exclusion or equivalent, if any	
		From DD/MM/YYYY	To DD/MM/YYYY

5 **DETAILED PARTICULARS OF PARTNERS/COMPANY DIRECTORS**

FULL NAME/ DESIGNATION	WORKING EXPERIENCE

6 **PARTICULARS AND EMPLOYMENT HISTORY OF PROFESSIONAL/SUPERVISORY/TECHNICAL STAFF/ACCOUNT MANAGER/PROJECT MANAGER**

	S/NO	NAME	QUALIFICATION	INSTITUTION	YEAR AWARDED	RELEVANT WORKING EXPERIENCE IN THE LAST 5 YEARS (WITH POSITION HELD & RESPONSIBILITIES)
1						
1						
2						
3						
4						

If space provided above is insufficient, please continue on an extension page setting out the required data in a similar manner

7 **CONTRACTS SECURED IN THE LAST 5 YEARS (EXCLUDE PROJECTS MENTIONED IN SECTION 8, IT/9)**

S/N	PROJECT TITLE AND DESCRIPTION OF PROJECT#	CLIENT (ORGANISATION, DEPARTMENT AND ADDRESS)	DURATION & VALUE OF CONTRACT (\$)	DATE OF COMMENCEMENT & COMPLETION (DD/MM/YY TO DD/MM/YY)	OFFICER-IN-CHARGE (JOB TITLE, DESIGNATION, EMAIL, TEL & FAX NO.)
Project/s of similar service and scale					
Other Project/s					

*If space provided above is insufficient, please continue on an extension page setting out the required data in a similar manner.
With reference to Firm/Company stated in Page IT/3, Section 1.*

8 **DETAILS OF CURRENT PROJECTS IN PROGRESS OR DUE TO BE EXECUTED (EXCLUDE PROJECTS MENTIONED IN SECTION 7)**

S/N	PROJECT TITLE AND DESCRIPTION OF PROJECT#	CLIENT (ORGANISATION, DEPARTMENT AND ADDRESS)	DURATION & VALUE OF CONTRACT (\$)	DATE OF COMMENCEMENT & COMPLETION (DD/MM/YY TO DD/MM/YY)	OFFICER-IN-CHARGE (JOB TITLE, DESIGNATION, EMAIL, TEL & FAX NO.)
Project/s of similar service and scale					
Other Project/s					

*If space provided above is insufficient, please continue on an extension page setting out the required data in a similar manner.
With reference to Firm/Company stated in Page IT/3, Section 1.*

9

CONTACT DETAILS FOR REFERENCE CHECK

S/N	PROJECT TITLE AND DESCRIPTION OF PROJECT#	CLIENT (ORGANISATION, DEPARTMENT AND ADDRESS)	OFFICER-IN-CHARGE (NAME & DESIGNATION)	OFFICER-IN-CHARGE (EMAIL)	OFFICER-IN-CHARGE (TEL NO.)

If space provided above is insufficient, please continue on an extension page setting out the required data in a similar manner.

With reference to Firm/Company stated in Page IT/3, Section 1.

10 **DECLARATION**

I/We declare that the information provided in this tender offer (including the prescribed forms) are correct and true.

I/We hereby undertake to inform SAS of any changes of partnership/director or firm/company taking place during the term of the Contract.

I/We agree that SAS may conduct reference checks with any of our past and existing clients that I/we have provided in Section 7, 8 and 9.

NAME AS IN NRIC/FIN AND SIGNATURE

DATE

(AUTHORISED REPRESENTATIVE)

COMPANY STAMP

IMPORTANT NOTES :

- (a) All items in Schedules 1, 2,3, Annex E and F (if applicable for Consortium) must be filled. Any items which are not applicable must be clearly stated. Incomplete forms shall render the Tender to be rejected.
- (b) All forms submitted must be signed by an Authorised Representative with company stamp and signatory on every page. The Authorised Representative must be the partner or director of the firm/company/ Consortium firms and legally empowered to act and endorse on behalf of the firm/company/Consortium firms.
- (c) For a Consortium Firms/Companies or a Partnership Firm, the forms must be accompanied by the latest copy of computer information (Business Profile) from the Accounting and Corporate Regulatory Authority (ACRA).
- (d) For a Limited Company, the forms must be accompanied by a Memorandum and Articles of Association and the latest copy of computer information (Business Profile) from ACRA.
- (e) Tenderer who fails to attach items as specified in (c) and (d) as indicated above and any other required supporting documents may render the Tender to be rejected.

Schedule 2 :
FORM OF TENDER

FORM OF TENDER

TO: SINGAPORE ARTS SCHOOL LTD.

TENDER (ITT) FOR REPLACEMENT OF VIDEO SHOW RELAY SYSTEMS WITH MAINTENANCE SERVICES AT SCHOOL OF THE ARTS, SINGAPORE

- 1 I/We, the undersigned having visited the site, hereby submit this **Tender for Replacement of Video Show Relay Systems with Maintenance Services at School of the Arts, Singapore** as specified in this Tender document in accordance with the Conditions of Contract (Annex A), Technical Requirements (Annex C), Scope of Works (Annex D), Statement of Compliance (Annex E) and if applicable, Consortium Declaration (Annex F) attached hereto, to the entire satisfaction of the Company.
- 2 My/Our Total Tender for the Contract is for Total Amount ("the Contract Sum") of Singapore Dollars: _____

(S\$ _____)
- (*Amount brought forward from Schedule 3. Schedule of Price, SOP/7, Total Contract Sum. The Contract Sum is deemed to exclude the Goods and Services Tax "GST".)*
- 3 Until a formal Contract is executed, this Tender together with your written acceptance thereof, will constitute a binding contract between us.
- 4 I/We understand that you are not bound to accept the lowest of any submitted Tender you may receive.
- 5 I/We further undertake that this offer will not be retracted or withdrawn for a period of ninety (90) days from the date fixed for receiving the same and it will remain binding upon me/us, and may be accepted or rejected at any time before the expiration of that period.
- 6 I/We understand that the Contract Period will commence within ninety (90) days of the Tender validity.
- 7 The actual commencement date of Works will be concluded upon the award of the Contract. The commencement date will be stated accordingly in the Company's Letter of Acceptance.
- 8 I/We agree to commence the Services on the date specified in the Company's Letter of Acceptance.
- 9 I/We understand that the Contract Sum will be paid to the Contractor based on the payment terms specified in Annex A - Conditions of Contract, COC/9, Clause 4.
- 10 I/We have not included any allowance in this Tender for payment to other Tenderers or to any Trade, Industry or Professional organisation acting independently or for or on behalf of any or all Tenderers.
- 11 I/We have read and understood all Selection Criteria (Annex B), Technical Requirements (Annex C), Scope of Works (Annex D) and Statement of Compliance (Annex E) and their relation to the Schedule of Price (Schedule 3) and confirm that this Total Amount as quoted in the Form of Tender (FOT/1 Point 2.) will include all items related to all documents as stated above.
- 12 I/We offer to provide the Material, Works, Equipment, Goods and Services at the prices submitted in the Tender based on the terms and conditions as stated in the Technical Requirements (Annex C) and Scope of Works (Annex D).

- 13 I/We understand that if my/our Tender is accepted, I/We will provide insurance coverage to indemnify the Company against all liabilities or claims for damages and/or injuries to my/our workmen and public as follows :

Insurance Coverage

- a) Public Liability Policy :
- i) In respect of any one accident the sum, of at least Singapore Dollars One Million Only (S\$1,000,000.00);
 - ii) For any one accident and for an unlimited number of accidents;
 - iii) Must be taken out and maintained at my/our cost and expense in the joint names of the Company and myself/ourselves with a reputable insurance company in Singapore;
 - iv) Singapore Arts School Limited will be clearly specified as part of the covered party whilst the contract is still valid; and
 - v) Coverage for damage to Persons and Property.
- b) Workmen's Compensation Policy in accordance with Work Injury Compensation Act.
- i) I/We will at all times observe and ensure compliance with Workplace Safety and Health Act, Work Injury Compensation Act, including all other applicable laws, regulations and requirements of any government or regulatory authority relating to safety, and bear all costs and expenses connected with the observance and compliance of the same.
- c) The insurance coverage is to be purchased from an insurance company approved by the Company within fourteen (14) days from the date of the letter of acceptance.
- 14 I/We warrant that I/We have obtained and will at all times during the subsistence of the Contract (including any renewal thereof) maintain all necessary licenses, approvals, permits, consents and/or other authorisation required by the Tenderer in order to fully perform and complete the works.
- 15 I/We will at all times observe and ensure compliance with Workplace Safety and Health Act, Work Injury Compensation Act, including all other applicable laws, regulations and requirements of any government or regulatory authority relating to safety, and bear all costs and expenses connected with the observance and compliance of the same.
- 16 I/We agree, in the event of this Tender being accepted by the Company, until a formal contract is prepared and executed between us, to be bound by and to observe and perform all the covenants and obligations on my/our part respectively contained in this Tender submission, together with the Company's written acceptance thereof and notification of award.
- 17 The Company reserves the absolute right to amend the required item(s) before or during the Contract Period or to terminate this Contract by serving to the Tenderer, thirty (30) days prior notice in writing.

NAME AS in
NRIC/FIN AND
SIGNATURE

:

(AUTHORISED
REPRESENTATIVE)

NAME AND
SIGNATURE
(WITNESS)

:

DESIGNATION
(AUTHORISED
REPRESENTATIVE)

:

DESIGNATION
(WITNESS)

:

DATE

:

DATE

:

COMPANY NAME
AND COMPANY
STAMP

:

Schedule 3 :
SCHEDULE OF PRICE

SCHEDULE OF PRICE**FOR REPLACEMENT OF VIDEO SHOW RELAY SYSTEMS WITH MAINTENANCE SERVICES AT SCHOOL OF THE ARTS, SINGAPORE**

The correct details of my/our offer for the proposed supply, dismantle, disposal, install, configure, synchronise, programming, testing and commissioning of video show relay systems with video recording capability in Drama Theatre, Concert Hall and Studio Theatre at School of the Arts, Singapore including preliminaries and profit, in accordance with the Conditions of Contract (Annex A), Technical Requirements (Annex C) and Scope of Works (Annex D) are as follows:

Section A: Price Break Down

S/N	Description	* UOM	Quantity	Proposed Brand and Model	Estimated Delivery Lead Time	Unit Price S\$	Total Price S\$
Concert Hall							
1	Network PTZ Camera (Refer to Annex C for equipment technical requirements)	Unit	3				
2	Network CCTV Camera (Refer to Annex C for equipment technical requirements)	Unit	7				
3	Network Infrared Camera (Refer to Annex C for equipment technical requirements)	Unit	1				
4	Network PTZ Camera Controller (Refer to Annex C for equipment technical requirements)	Unit	1				
5	Network Video Recorder (Refer to Annex C for equipment technical requirements)	Unit	1				
6	Touchscreen Tablet Controller (Refer to Annex C for equipment technical requirements)	Unit	2				
7	55" Smart TV (Refer to Annex C for equipment technical requirements)	Unit	3				

8	32" Smart TV (Refer to Annex C for equipment technical requirements)	Unit	13				
9	48 Port Network Switch (Refer to Annex C for equipment technical requirements)	Unit	1				
10	8 Port Network Switch (Refer to Annex C for equipment technical requirements)	Unit	1				
11	AVOIP Media Processor Workstation (Refer to Annex C for equipment technical requirements)	Unit	2				
12	IP Media Decoder (Refer to Annex C for equipment technical requirements)	Unit	4				
13	HDMI to SDI Converter (Refer to Annex C for equipment technical requirements)	Unit	4				
14	Stage Manager Control Desk (Refer to Annex C for equipment technical requirements)	Unit	1				
15	Concert Hall – Installation Installation of Video Show Relay System in Concert Hall including dismantle, dispose, install, configure, synchronise, programming, testing and commissioning of the systems (Refer to Annex C for equipment technical requirements and Scope of Works in Annex D)	Lot	1				
Sub-Total for Concert Hall: subject to GST & its prevailing rate							(CH)

S/N	Description	* UOM	Quality	Proposed Brand and Model	Estimated Delivery Lead Time	Unit Price S\$	Total Price S\$
Drama Theatre							
1	Network PTZ Camera (Refer to Annex C for equipment technical requirements)	Unit	2				
2	Network CCTV Camera (Refer to Annex C for equipment technical requirements)	Unit	6				
3	Network Infrared Camera (Refer to Annex C for equipment technical requirements)	Unit	1				
4	Network PTZ Camera Controller (Refer to Annex C for equipment technical requirements)	Unit	1				
5	Network Video Recorder (Refer to Annex C for equipment technical requirements)	Unit	1				
6	Touchscreen Tablet Controller (Refer to Annex C for equipment technical requirements)	Unit	2				
7	55" Smart TV (Refer to Annex C for equipment technical requirements)	Unit	3				
8	32" Smart TV (Refer to Annex C for equipment technical requirements)	Unit	14				
9	48 Port Network Switch (Refer to Annex C for equipment technical requirements)	Unit	1				
10	8 Port Network Switch (Refer to Annex C for equipment technical requirements)	Unit	1				
11	AVOIP Media Processor Workstation (Refer to Annex C for equipment technical requirements)	Unit	1				

12	IP Media Decoder (Refer to Annex C for equipment technical requirements)	Unit	4				
13	HDMI to SDI Converter (Refer to Annex C for equipment technical requirements)	Unit	4				
14	Stage Manager Control Desk (Refer to Annex C for equipment technical requirements)	Unit	1				
15	Drama Theatre – Installation Installation of Video Show Relay System in Drama Theatre including dismantle, dispose, install,configure, synchronise, programming, testing andcommissioning of the systems (Refer to Annex C for equipment technical requirements and Scope of Works in Annex D)	Lot	1				
Sub-Total for Dance Theatre: subject to GST & its prevailing rate							(DT)

S/N	Description	* UOM	Quality	Proposed Brand and Model	Estimated Delivery Lead Time	Unit Price S\$	Total Price S\$
Studio Theatre							
1	Network PTZ Camera (Refer to Annex C for equipment technical requirements)	Unit	1				
2	Network CCTV Camera (Refer to Annex C for equipment technical requirements)	Unit	4				
3	Network Infrared Camera (Refer to Annex C for equipment technical requirements)	Unit	1				
4	Network PTZ Camera Controller (Refer to Annex C for equipment technical requirements)	Unit	1				
5	Network Video Recorder (Refer to Annex C for equipment technical requirements)	Unit	1				
6	Touchscreen Tablet Controller (Refer to Annex C for equipment technical requirements)	Unit	2				
7	55" Smart TV (Refer to Annex C for equipment technical requirements)	Unit	1				
8	32" Smart TV (Refer to Annex C for equipment technical requirements)	Unit	7				
9	24 Port Network Switch (Refer to Annex C for equipment technical requirements)	Unit	1				
10	AVOIP Media Processor Workstation (Refer to Annex C for equipment technical requirements)	Unit	1				
11	IP Media Decoder (Refer to Annex C for equipment technical requirements)	Unit	4				
12	HDMI to SDI Converter (Refer to Annex C for equipment technical requirements)	Unit	4				

13	Stage Manager Control Desk (Refer to Annex C for equipment technical requirements)	Unit	1				
14	Studio Theatre – Installation Installation of Video Show Relay System in Studio Theatre including dismantle, dispose, install, configure, synchronise, programming, testing and commissioning of the systems. (Refer to Annex C for equipment technical requirements and Scope of Works in Annex D)	Lot	1				
Sub-Total for Studio Theatre: subject to GST & its prevailing rate							(ST)

Note: Above prices quoted are to include all Shipping Charges, Dismantling, Disposal, Configuring, Synchronising, Programming, Testing, Installation, Commissioning, Training, Maintenance, and Servicing of Video Show Relay Systems with Video Recording Capability in Drama Theatre, Concert Hall, and Studio Theatre at the School of the Art, Singapore, and any other incidental costs as per Technical Requirements (Annex C) and Scope of Works (Annex D).

* Unit of Measure (UOM)

Section B. Total Contract Sum

Total Contract sum is calculated based on the Sub-Total brought over from Section A for each venue.

Venue	Sub-Total
Concert Hall (CH)	S\$ _____ (i)
Drama Theatre (DT)	S\$ _____ (ii)
Studio Theatre (ST)	S\$ _____ (iii)
<p><i>*This part to be filled in the FOT/1, Point 2, the Contract Sum tendered.</i></p> <p style="text-align: right;">Total Contract Sum: subject to GST & its prevailing rate</p>	<p>S\$ _____</p> <p>(i) + (ii) + (iii)</p>

IMPORTANT NOTES:

All prices submitted are in accordance to the corresponding Schedules, Annexes and Appendices. All details must be verified by the Tenderer during Tender Briefing and Site-Show.

I/We fully understand and agree that notwithstanding the fact that the Contract Sum as herein quoted by us is applicable to the Technical Requirements and Scope of Works specified.

Dated this _____ day of _____ 202_

NAME AND SIGNATURE (AUTHORISED REPRESENTATIVE) : _____

DESIGNATION (AUTHORISED REPRESENTATIVE) : _____

DATE : _____

NAME AND SIGNATURE (WITNESS) : _____

DESIGNATION (WITNESS) : _____

DATE : _____

COMPANY NAME AND COMPANY STAMP : _____

Annex A :
CONDITIONS OF CONTRACT

DATED THIS ____ DAY OF _____

BETWEEN

SINGAPORE ARTS SCHOOL LTD
(the "Company")

(the "Contractor")

CONTRACT

(Tender reference: SAS/OP/2024/013/T)

CONTENTS

1. DEFINITIONS AND INTERPRETATION
2. APPOINTMENT AND SCOPE OF CONTRACT
3. DUTIES AND OBLIGATIONS OF CONTRACTOR
4. CONTRACT SUM
5. COMMENCEMENT OF WORKS
6. POWER TO ENGAGE OTHER CONTRACTORS
7. COMPLETION DATE
8. DEFECTS LIABILITY PERIOD
9. INTELLECTUAL PROPERTY
10. TERMINATION
11. SUSPENSION
12. INDEMNITY AND INSURANCE
13. FORCE MAJEURE
14. LIQUIDATED DAMAGES
15. NOTICES
16. WAIVER
17. SEVERABILITY
18. ENTIRE AGREEMENT AND MODIFICATION
19. NO PARTNERSHIP
20. SUB-CONTRACT AND ASSIGNMENT
21. COSTS
22. CONFIDENTIALITY
23. VARIATION
24. COUNTERPARTS
25. CONTRACTS (RIGHTS OF THIRD PARTIES) ACT
26. GOVERNING LAW AND JURISDICTION

- | | | |
|--------------|---|---|
| SCHEDULE 1 | : | INSTRUCTION TO TENDERERS |
| SCHEDULE 2 | : | FORM OF TENDER |
| SCHEDULE 3 | : | SCHEDULE OF PRICE |
| ANNEX A | : | CONDITIONS OF CONTRACT |
| ANNEX B | : | SELECTION CRITERIA |
| ANNEX C | : | TECHNICAL REQUIREMENTS |
| ANNEX D | : | SCOPE OF WORKS |
| ANNEX E | : | STATEMENT OF COMPLIANCE |
| ANNEX F | : | CONSORTIUM DECLARATION |
| APPENDIX i | : | VIDEO SHOW RELAY SYSTEM EQUIPMENT LAYOUT PLAN |
| APPENDIX ii | : | VIDEO SHOW RELAY SYSTEM SIGNAL BLOCK DIAGRAM |
| APPENDIX iii | : | TECHNICAL SPECIFICATION FOR STAGE MANAGER CONTROL
DESK |

THE CONTRACTOR'S TENDER DOCUMENT DATED _____.
 THE COMPANY'S ITT DOCUMENT REF SAS/OP/2024/013/T.

THIS CONTRACT ("**Contract**") is made on the ____ day of _____ 202_

BETWEEN:

(1) **SINGAPORE ARTS SCHOOL LTD.** (Company Registration No. 200500775C), a company incorporated in Singapore and having its registered address at 1 Zubir Said Drive, #05-01, Singapore 227968 (the "**Company**"); and

(2) _____ (Company Registration No. _____), a company incorporated in Singapore and having its registered address at _____ (the "**Contractor**"),

(each a "**Party**" and together the "**Parties**").

WHEREAS:

(A) The Company operates and manages the School of the Arts, Singapore (the "**Arts School**"), a specialised pre-tertiary arts school established by the Ministry of Culture, Community and Youth (MCCY).

(B) On _____, the Company invited proposals for the Tender for Replacement of Video Show Relay Systems with Maintenance Services at School of the Arts, Singapore.

(C) The Company has agreed to engage the Contractor to perform the Works (as defined below) upon the terms and conditions contained herein.

(D) This Contract shall comprise of and, in the event of any conflict, inconsistency or discrepancy, shall be in the following order of precedence:

- i) This Contract;
- ii) The Contractor's Proposal dated: _____; Proposal ref: _____
- iii) The Company's tender document ref: SAS/OP/2024/013/T

THE PARTIES HEREBY agree as follows:

1. DEFINITIONS AND INTERPRETATION

1.1 In this Contract, the following words have the following meanings unless inconsistent with the context:

“Authorised Representatives” representatives of the Contractor who are authorised by the Company in writing from time to time.

“Authorities” relevant authorities who have jurisdiction over the Works whether temporarily or permanently.

“Business Day” a day (excluding Saturdays, Sundays and public holidays) on which banks generally are open in Singapore for the transaction of normal banking business.

“Confidential Information” all information of a confidential nature relating to the Company or the Arts School, including without limitation, marketing plans, business strategies, financial information and forecasts, personnel information and other information concerning the Company's and the Arts School's operations and plans. For the purpose of this definition, information which is regarded as confidential includes any document marked “confidential” or any information which the Contractor is told or is aware is confidential, or which the Company might reasonably regard as confidential.

“Consortium” an unincorporated joint venture through the medium of a consortium or a partnership.

“Contract” means the Contract Agreement, together with the tender documents referred to therein including the Instructions to Tenderers, Form of Tender, Conditions of Contract, Technical Requirements, Scope of Works, Statement of Compliance, Consortium Declaration, Letter of Acceptance and all these documents taken together shall be deemed to form the Contract;

“Materials” such software programs, equipment, system, hardware, apparatus, manuals and/or other goods to be delivered to the Company by the Contractor in connection with carrying out the Works.

“SAS Authorised Personnel” representative who shall be nominated by the Company to be in charge of supervising the Works.

“Site” the site on the Company's premises where the Works are to be carried out.

“Specifications” the Technical Requirements as set out in Annex C.

“Works” the Scope of Works as set out in Annex D.

1.2 The headings to the clauses of and schedules to this Contract are for convenience only and shall not affect the construction or interpretation thereof.

1.3 References to a statute or statutory provision shall, unless the context otherwise requires, include a reference to that statute or statutory provision as from time to time amended, modified,

extended, re-enacted, consolidated and all statutory instruments or orders made pursuant to it whether replaced before or after the date of this Contract.

- 1.4 Any reference in this Contract to a "Clause", "Schedule", "Appendix" or "Annex" is a reference to a clause of or schedule to or annex to this Contract.
- 1.5 Unless the context otherwise requires, references to the singular number shall include references to the plural number and vice versa, references to natural persons shall include bodies corporate, and the use of any gender shall include all genders.

2. APPOINTMENT AND SCOPE OF CONTRACT

- 2.1 The Company hereby appoints the Contractor to carry out the Works and provide the Materials, and the Contractor hereby accepts such appointment, upon the terms and conditions hereinafter set forth.
- 2.2 The Contractor shall carry out and complete the Works in accordance with the directions and to the satisfaction of the SAS Authorised Personnel, and agrees that the SAS Authorised Personnel shall be entitled to order:
- (a) any variation or modification of the design, quality or quantity of the Works and/or the addition or omission or substitution of any Works;
 - (b) the removal from the Site and replacement of any material brought thereon by the Contractor;
 - (c) the removal and/or re-execution of the Works or any part thereof executed by the Contractor; and
 - (d) the making good of any defects in the Works.
- 2.3 The Contractor shall be deemed to have ascertained for itself the nature and full extent of the Works comprised in this Contract and to have satisfied itself, at its own cost and expense, as to the correctness and sufficiency of its Proposal and Tender. The Company shall not be liable to the Contractor for any claims arising from the Contractor's default in ascertaining for itself any information with regard to its obligations or from any increase in costs and expenses as a result thereof.
- 2.4 Where this Contract has been awarded to a Consortium, the Contract shall be binding on all the members of the Consortium and each member of the Consortium shall be jointly and severally responsible to the Company for the due performance of the Contract. In the event that any member of the Consortium withdraws from the Consortium, is adjudicated a bankrupt, goes into liquidation or is otherwise unable to perform under this Contract, the surviving member(s) of the Consortium shall carry out and complete the performance of the Contract.

3. DUTIES AND OBLIGATIONS OF CONTRACTOR

3.1 Performance of Works

- (a) The Contractor shall:
- (i) carry out the Works in a diligent and expeditious manner;
 - (ii) ensure that the Materials provided are of a consistently high quality; and
 - (iii) at all times act with the utmost good faith towards the Company and use its best endeavours to anticipate the needs of the Company and the Arts School and be creative, responsive and proactive towards such needs.

- (b) The Contractor acknowledges that it is and shall remain personally liable for the consequences of any failure on its part, or the part of any third party appointed, to carry out the Works in accordance with the terms of this Contract.
- (c) The Contractor's representative will be required to attend all meetings as called by the Company from time to time to ensure the smooth carrying out of the Works.
- (d) The Contractor shall carry out the Works with the minimum of noise and no nuisance in any form shall be created.
- (e) The Contractor shall arrange for the conveyance of his materials, plant etc. so as to cause a minimum of damage to existing properties. The Contractor shall be held responsible for any damage caused by his lorries, agents, tools or plants to any property from whatsoever cause arising and shall maintain, repair and reinstate the same to its original condition to the satisfaction of the Company.

3.2 Compliance

- (a) The Contractor shall ensure that the execution of the Works complies with all relevant laws, regulations, rules, orders and bye-laws and shall give such notices as may be necessary to the authorities in connection with the Works.
- (b) The Contractor shall at its own cost ensure that all licences, authorisations and permits necessary to enable the Contractor to fulfil all its obligations under this Contract have been obtained and are in full force and effect for the duration of this Contract, and that all conditions applicable to any such licence, authorisation or permit have been and will be complied with. The Contractor shall indemnify and keep the Company indemnified from any penalties, fines or claims resulting from the failure by the Contractor to (i) obtain and maintain any such licences, authorisations and permits, or (ii) comply with the conditions applicable to such licences, authorisations and permits. The Contractor shall submit copies of all licences, authorisations and permits obtained to the Company for the Company's records.
- (c) The Contractor further undertakes to ensure that all statutory and regulatory requirements relating to, *inter alia*, the immigration status of the workers, employees or agents conducting the Works shall be fully complied with. The Contractor shall be held fully and solely liable for and shall indemnify the Company and SAS Authorised Personnel in respect of all actions taken against the Company and SAS Authorised Personnel for employing foreign workers without valid permits.
- (d) In the event of default being made in the payment of any monies in respect of wages and/or Central Provident Fund contributions of any workmen employed by the Contractor in and for the performance of this Contract, and if a claim therefor is filed with the Ministry of Manpower, and proof thereof is furnished to the satisfaction of an officer of the said Ministry, the Company may, failing the payment of the said monies by the Contractor, make payment of such claim to the said Ministry out of any sums due or to become due to the Contractor.
- (e) The Contractor shall implement and comply with all rules and regulations, safety requirements and security requirements notified to it by the Company or any relevant authorities.

3.3 Safety

- (a) The Contractor shall comply with all relevant laws, regulations and requirements of all relevant authorities in relation to occupational health and safety, including but not limited to the Workplace Safety and Health Act (Cap. 354A), the Workplace Safety and Health (General Provisions) Regulations, the Environmental Protection and Management Act (Cap. 94A) and the Environmental Public Health Act (Cap. 95).

- (b) The Contractor shall take every reasonable precaution to ensure the safety of the Company and any other person at the Site or in the vicinity of the Site whilst the Works are being carried out, including but not limited to displaying warning and/or caution signs at prominent locations around the Site and cordoning off the Site whilst the Works are being carried out.
- (c) The Contractor shall put up suitable new closed-boarded perimeter 20mm thick plywood hoarding to ceiling height, temporary secure escape doors and exit signs to give sufficient protection and enclosure and ensure that rules and regulations relating to means of escapes are complied with.
- (d) The Contractor shall provide, maintain and remove such temporary hoardings and gantries when no longer required or directed by the Company and make good all areas affected by the temporary work.
- (e) All hoardings must be painted with 2 coats of selected emulsion paint to the approval of the Company and with signs stating "Construction Work in Progress", "Sorry for the Inconvenience Caused" and "Expected Date of Completion" etc. to the approval of the Company.
- (f) The Contractor shall put up suitable warning signs in the four official languages of the Republic of Singapore at all access points to the site to safeguard against trespassing by unauthorised persons.
- (g) The Contractor shall prepare and submit a full risk management plan to the satisfaction of the Company. The Contractor shall monitor and update the plan on a regular basis.

3.4 Premises, Materials and Equipment

(a) Contractor to provide everything necessary

The Contractor shall provide and do everything necessary for the proper execution of the Works.

(b) Materials

- (i) All materials and equipment used in carrying out the Works shall be new and so far as procurable be of best of the respective kinds described in the Specifications and the Contractor shall upon the request of the SAS Authorised Personnel furnish him with vouchers to prove that the materials comply therewith. The Contractor shall arrange for and/or carry out any test of any materials or equipment which the SAS Authorised Personnel may in writing require and the cost thereof shall be added to the Contract Sum (as defined below) unless provided for in the Specifications by way of provisional sum or otherwise or unless the test shows that the said materials and/or equipment are not in accordance with the Specifications.
- (ii) The Contractor shall remain liable for any breach of Clause 3.4(b)(i) notwithstanding that the Company has accepted the Works as having been satisfactorily executed or completed.
- (iii) Samples of materials are to be supplied free of charge to the Company at the Company's instruction for approval before such materials are built or incorporated into the Works.
- (iv) All materials shall be transported, handled and properly stored on site in such a manner as to minimise and prevent damage, deterioration or contamination etc.

- (v) All materials that are old, deteriorated, damaged, contaminated or not equal to approved sample or specification will be rejected and shall be removed from the Site at the Contractor's own expense.
- (vi) The Contractor shall place its orders for all materials at the earliest possible date after award of the Contract and shall be held responsible for any delay occasioned by its failure to do so.

(c) Unfixed materials

Where the Contractor has received payment in respect of any unfixed materials intended for incorporation in the Works and placed on or adjacent to the Site, such materials, the loss of or damage of which shall be the Contractor's responsibility, shall not be removed (except for use in connection with the Works) without the prior written consent of the SAS Authorised Personnel.

(d) Protection of premises and property

The Contractor shall be responsible for any damage or loss that may occur to the premises of the Arts School and any property situated thereon or otherwise belonging to the occupiers of or visitors to the Arts School, which occurs as a result of, whether directly or indirectly, the carelessness, negligence, default or otherwise of the Contractor or persons employed by it in the performance of their duties. Any such damage or loss shall be made good or replaced by the Contractor to the satisfaction of the SAS Authorised Personnel or the occupiers or visitors concerned, whichever is applicable. If such damage or loss is not made good or replaced by the Contractor, the Company shall be entitled to deduct the cost of such remedying such damage or loss from any moneys due or which may become due to the Contractor.

(e) Protection of Works

The Contractor shall provide all things necessary for the protection of the Works and all unfixed materials and goods delivered upon the site of the Works, whether delivered by the Contractor or the Company for use upon the Works, and the Contractor shall assume full responsibility for any damage sustained to the foregoing from whatever cause arising.

(f) Protection of service media

The Contractor shall protect, uphold, maintain and seal off where necessary all existing water, gas, electricity and telephone lines, drains etc., unless earmarked for demolition, during the execution of the Works. The Contractor is to make good any damage due to any cause within his control at his own expense or pay any costs with charges in connection therewith. Where the services are to be temporarily terminated or diverted, the Contractor is to give the necessary notice to the Company and to arrange for the work to be carried out and pay all costs and charges in connection therewith.

(g) Water, electricity and temporary installations

- (i) All water and electricity required for the proper and efficient execution of the Works will be provided free of charge by the Company, but the Contractor will be expected to exercise every effort to prevent the abuse of this privilege and to economise in the use of water and electricity, and to ensure that all rules and regulations applicable to the use of same are strictly complied with by the Contractor's workers.
- (ii) The Contractor shall power and maintain (or arrange for the use of existing facilities) all wiring and accessories for the temporary installation of electric lighting and power necessary for the Works, and pay all charges connected therewith.

- (iii) The Contractor shall remove all temporary installations when directed by the Company and make good the Site thereafter.

(h) Scaffolding and staging

The Contractor shall provide and maintain all necessary temporary scaffolding together with planks, battens, catwalks, gangways, ladders, etc, and provide special staging where required in positions of unusual height or construction for the proper execution and completion of the Works, including those of sub-contractors, and pay all costs and charges in connection therewith.

(i) Cleaning up on completion

The Contractor shall remove all refuse from the site on completion of the Works. Should the Contractor fail to remove refuse from the site after reasonable notice in writing has been given by the Company, and if the progress of the Works is impeded by such failure, the Company reserves the right to employ outside labour to remove the refuse and deduct all costs and expenses thereby incurred from any money due or which may become due to the Contractor.

(j) Protection of plant and materials

- (i) The Contractor shall be fully responsible for all equipment, tools, apparatus and materials provided by him in connection with the Works, and special care shall be taken to protect all parts thereof in such a manner as may be necessary or as directed by the Company.

- (ii) This protection shall include covers, sheds, stores or other means to prevent water, dirt, grit, plaster or other foreign substances from entering the working parts of machinery and to protect the equipment and materials from the weather. Special care shall be taken to keep all open ends of pipes, ducts, etc., closed in storage or in the course of carrying out the Works.

(k) Use of lifts, loading bays and access areas

The Contractor shall comply with all directions given by the Company from time to time as to the use of lifts, loading bays and access areas within the Company's premises.

3.5 Site Staff

- (a) The Contractor shall take all reasonable precautions to ensure that all persons employed by it to carry out the Works are competent and have experience performing such Works.

- (b) The Contractor shall ensure that such persons employed shall comply with and observe all of the Company's internal rules and procedures which may be prescribed by the Company from time to time in connection with the performance of the Works and shall comply with any and all instructions given by the Company to the Contractor in connection therewith.

- (c) The Contractor shall be responsible for keeping all persons under its control or employ, including persons employed by sub-contractors, within the boundaries of the Site.

3.6 Security and Screening of Employees

- (a) Before the Contractor employs or engages any person in connection with the Works, the Contractor shall ensure that it has, in respect of that person:

- (i) obtained a police records check (if required by the Company); and
- (ii) investigated the person's employment history,

and satisfied itself that based on the foregoing, the person is a suitable person to be so employed.

- (b) The Contractor shall provide to the Company all information relating to the screening process described in Clause 3.6(a) above, and the Company shall provide the Contractor with the names of those persons (if any) that the Company has approved in relation to the screening process (the "**Approved Persons**").
- (c) The Company may at any time notify the Contractor that a person has ceased to be an Approved Person. Upon receipt of such notice, the Contractor shall ensure that such Approved Person shall no longer enter the Company's premises, and that such Approved Person shall cease to be engaged in connection with the Works.
- (d) The Contractor shall provide its own security guards, as necessary, to protect the Works and ensure that all the Company's fixtures, fittings and equipment are properly guarded and protected from theft, burglary, accidents and loss.

4. CONTRACT SUM

- 4.1 The Company shall pay the Contractor _____ (the "**Contract Sum**") for carrying out the Works and providing the Materials.
- 4.2 The Contract Sum is exclusive of Goods and Services Tax and shall be paid to the Contractor 30 days upon acceptance and receipt of invoice after the satisfactory delivery of works.
- 4.3 The Company shall be entitled to deduct and set-off from any payments due to the Contractor under this Contract against any monies which may from time to time become due and owing to the Company by the Contractor.
- 4.4 This Contract is on a "fixed price" basis and no variations in the rates of labour, prices of any materials and schedule of unit rates bid shall be allowed unless specified and approved by the Company. Unless otherwise specifically stated, the following shall be deemed to be included in the Contract Sum:
 - (a) Labour and all costs in connection therewith;
 - (b) Materials, goods and costs in connection therewith (e.g. conveyance, delivery, unloading, carrying in, storing, returning packages, handling, hoisting and placing or lowering);
 - (c) Fitting and fixing materials and goods in position;
 - (d) Removing existing fittings or fixtures where necessary for carrying out the Works;
 - (e) Use of plant, tools and vehicles, including warranty, and supply of fuel, and other equipment necessary for the proper execution and completion of the Works;
 - (f) Waste of materials;
 - (g) Establishment charges, supervision attendance, overhead charges and profit; and
 - (h) Complying with the requirements of the Contract and any other requirement necessary for the proper execution and completion of the Work.

5. COMMENCEMENT OF WORKS

5.1 Possession of Site

- (a) The Company shall give the Contractor possession of so much of the Site as may be required to enable the Contractor to commence carrying out the Works stated in Scope of Works (Annex D). The Contractor shall not be entitled to claim against the Company for any loss or damage whatsoever caused by or related to any delay in giving possession of the Site.
- (b) The Contractor shall be deemed to have visited and examined the Site before submitting the Proposal and Tender and warrants that it is satisfied that the Site is suitable and meets all requirements for the Works and that it is satisfied as to the means of access, facilities for the transport and movement of materials and goods and plan for any contingency which may affect its Tender.
- (c) The Contractor shall not conduct any activities on the Site other than carrying out the Works.

5.2 Commencement of Works

- (a) Subject to Clause 6.2, upon receiving possession of the Site, the Contractor shall immediately commence carrying out the Works in a diligent and expeditious manner.
- (b) The Works shall be proceeded with in such order as the Company may direct, or in the absence of such instruction, in the most workmanlike manner.

5.3 Hours of Work

- (a) The following are the hours within which works can be carried out subject to the Company's approval with respect to school and venue operations.:

Monday to Friday (except Public Holidays)	- 0830hrs to 2130hrs
Remarks:	- All noisy works to be declared to Office of Venue Management (OVM) and carried out during the Company approved date and time.
- (b) The Company reserves the right to stop any works anytime if the works disturb the other occupiers in the Company premises or in the neighbouring buildings.
- (c) Notwithstanding the foregoing, the Company may direct the Contractor to carry out the Works on other days or at other times instead, at no extra charge. All Works must be carried out with due diligence and expedition as directed by the Company.

5.4 Access by SAS Authorised Personnel

The SAS Authorised Personnel and any person authorised by him shall at all reasonable times have access to the Site and all workshops and other places where the Works or preparations for the Works are being carried out. The Contractor shall use its best endeavours to facilitate the examination of the Works and/or Materials by the SAS Authorised Personnel and his authorised persons.

5.5 Drawings and Specification

The Contractor shall be responsible for the proper and accurate setting out of the Works, and shall keep one copy of this Contract, which shall include all Schedules, Annexes and

Appendices hereto, on the Site at all times, and the SAS Authorised Personnel shall have access to the same at all times. Any deviation from the setting out shown in the drawings shall be highlighted to the Company with sufficient notice.

5.6 Foreman and Assistants

The Contractor shall keep stationed on the Site an appropriately trained and competent general foreman and such assistants in each trade as may be necessary, each of whom must be capable of receiving verbal instructions in English, in default of which they may be supplied by the Company at the Company's sole discretion and all expenses in connection therewith shall be recoverable from the Contractor. The foreman and his assistants shall be deemed to have the full authority of the Contractor to receive and act upon the instructions of the SAS Authorised Personnel and any such instructions given to the foreman or his assistants shall be deemed to have been given to the Contractor.

5.7 Wage Book and Time Sheets

The Contractor shall:

- (a) keep proper wage books and time sheets showing the wages paid to and the time worked by all workers employed in carrying out the Works;
- (b) produce such wages books and time sheets on demand for inspection by any person duly authorised by the SAS Authorised Personnel or the relevant authorities; and
- (c) furnish such information relating to the wages and conditions of the employment of such workers as any person duly authorised by the SAS Authorised Personnel or the relevant authorities may from time to time require.

5.8 Defects

- (a) Any defects, imperfections, shrinkage or other faults which may appear during the progress of the Works, arising in the opinion of the SAS Authorised Personnel from materials or workmanship not being in accordance with the Contract, shall upon the directions in writing of the SAS Authorised Personnel, and within such reasonable time as shall be specified therein, be amended and made good by the Contractor at its own cost.
- (b) Should any defective work have been done or material supplied by any approved contractor employed on the Works, the Contractor shall be liable to make good the work in the same manner as if such work or material had been done or supplied by the Contractor.

5.9 Account, Receipts and Vouchers

The Contractor shall upon request of the SAS Authorised Personnel furnish him with all invoices, accounts, receipts and other vouchers that he may require in connection with this Contract.

6. POWER TO ENGAGE OTHER CONTRACTORS

- 6.1 If the Contractor, after receipt of a written notice from the SAS Authorised Personnel requiring compliance with such instructions of the SAS Authorised Personnel within the time stipulated in the notice, fails to comply with such instructions, the Company may at its sole discretion on the expiry of the time stipulated in the notice employ and pay other persons to execute any work whatsoever which may be necessary to give effect thereto and all costs and expenses incurred in connection therewith shall be recoverable from the Contractor by the Company as

a debt or may be deducted by the Company from any moneys due or becoming due to the Contractor.

- 6.2 The Company reserves the absolute right and power to engage other contractors to execute and/or perform any part of the Works and/or services relating to the Works which in its opinion are specialised in nature.

7. COMPLETION DATE

The Contractor shall complete the Works on or before the progressive completion dates stated in Purchase Order. Any requests to extend the Completion Date shall be in writing and must be received by the Company at least two (2) weeks before the Completion Date.

8. DEFECTS LIABILITY PERIOD

In the event that any defect, imperfection, shrinkage or other fault howsoever caused appears in the Works at any time within period stated from the completion of the Works, the Contractor shall, within a reasonable time after receipt of the SAS Authorised Personnel's written instructions, remedy such defect at its own cost and to the satisfaction of the SAS Authorised Personnel. (if applicable)

9. INTELLECTUAL PROPERTY

The Contractor agrees that any intellectual property rights that may arise out of or in connection with this Contract shall vest in the Company, and the Contractor shall, if so required by the Company at any time, execute a separate agreement (in such form as may be stipulated by the Company) to ensure that such intellectual property rights are fully and adequately vested in the Company. Notwithstanding the foregoing, the Contractor warrants that the Company's use of the Materials and/or the completed Works does not infringe the intellectual property rights of any third party and agrees to indemnify and keep the Company indemnified against any and all claims of infringement, save and except where such infringement is due solely to the use of any Specification or drawings provided by the Company for the purposes of this Contract.

10. TERMINATION

10.1 Termination for Breach

If at any time any of the following events shall occur:-

- 10.1.1. the Contractor is in breach of any of the terms or conditions of this Contract, (i) where such breach is capable of remedy, the Contractor fails to effect a remedy (at its own expense) within fourteen (14) days, then the Company may terminate this Contract without any liability with thirty (30) days termination written notice; or (ii) where such breach is not capable of remedy, then the Company may terminate this Contract without any liability with thirty (30) days termination written notice, or
- 10.1.2. the Contractor is unable to pay its debts generally as they become due, or any step or action is commenced against or by the Contractor for liquidation, dissolution, or if any judicial manager, trustee or receiver is appointed with respect to the Contractor's assets; or if the Contractor makes any form of compromise or scheme of arrangement with its creditors, or ceases to carry on business, then the Company may terminate this Contract without any liability with immediate notice.

10.2 Termination by Notice

10.2.1. Without prejudice to Clause 10.1 above, either Party may terminate this Contract on giving not less than 1 months' written notice to the other Party, without any requirement to furnish reasons for the termination and without any liability.

10.2.2. Termination of this Contract (whether under Clause 10.1, 10.2, 13 or otherwise) shall not affect any rights, remedies, obligations or liabilities of the Parties that have accrued up to the date of termination, including the right to claim damages in respect of any breach of the Contract which existed at or before the date of termination.

11. SUSPENSION

The Company is entitled to suspend this Contract either wholly or partially, upon giving three (3) days' notice in writing to the Contractor. The Contractor shall resume its full obligations under the Contract upon the cessation of the suspension period.

12. INDEMNITY AND INSURANCE

12.1 The Contractor undertakes to duly insure all workers engaged in the performance of the Works against any liability and further undertakes to indemnify and keep the Company and **SAS Authorised Personnel** indemnified against any and all loss, damage or liability (whether criminal or civil) suffered, together with legal costs on a full indemnity basis, as a result of the breach of this Contract by the Contractor, including but not limited to:

- (a) any act of neglect or default of the Contractor's employees, agents and/or permitted sub-contractors;
- (b) any breach in respect of any matter arising from the non-performance of the Works resulting in any claim by any third party; and
- (c) any breach of the Contractor's undertakings or warranties set out in this Contract.

12.2 The indemnities given by the Contractor under this clause shall not be defeated or prejudiced by reason of any negligence or omission of the Company or **SAS Authorised Personnel** in (i) supervising or controlling the Contractor's methods of performing the Works, (ii) detecting, preventing, remedying or mitigating defective Works, or (iii) ensuring the proper performance of any obligation of the Contractor under this Contract.

12.3 The contractor shall apply for and obtain all necessary insurances to safeguard the Company from unmitigated risks, accidents and unforeseeable elements, such as

- (a) Workmen compensation insurance (minimum of S\$1,000,000);
- (b) Public liability insurance (minimum of S\$1,000,000);
- (c) Any other applicable insurances as may be fit and justifiable as an expense to mitigate risks.

13. FORCE MAJEURE

Neither Party shall be liable for any failure or delay in performing its obligations under this Contract if the failure or delay is due to acts of God, acts of civil or military authority, wars, riots, civil commotions, strikes, lock-outs, fires or other catastrophes.

14. LIQUIDATED DAMAGES

Subject to Clause 13 (*Force Majeure*), if the Contractor fails to complete the Works by the Completion Date, the Contractor shall pay to the Company. Such sum shall be paid as liquidated and ascertained damages by the Contractor to the Company and the parties agree that such sum is fair and reasonable. (Annex D, Section B)

15. NOTICES

15.1 Any notice or other communication given to a Party under or in connection with this Contract shall be in writing and shall be:

15.1.1 delivered by hand or by pre-paid post or other next working day delivery service at its address as set out in clause 15.2; or

15.1.2 sent by email to the address specified in clause 15.2.

15.2 The addresses and email addresses for service of notices are as follows:

The Company	Singapore Arts School Ltd. 1 Zubir Said Drive Administration Office #05-01 Singapore 227968 Email: procurement@sota.edu.sg
The Contractor	[]

15.3 Any notice or communication shall be deemed to have been received:

15.3.1 if delivered by hand, on signature of a delivery receipt;

15.3.2 if sent by pre-paid post or other next working day delivery service, at 8.30am on the second Business Day after posting or at the time recorded by the delivery service; and

15.3.3 if sent by email, at the time of transmission, or, if this time falls outside business hours in the place of receipt, when business hours resume. In this clause 15.3, business hours means 9.00am to 6.00pm Monday to Friday on a day that is a Business Day.

15.4 This clause does not apply to the service of any proceedings or other documents in any legal action or, where applicable, any arbitration or other method of dispute resolution.

16. WAIVER

No failure or delay on the part of any Party hereto in exercising any power or right hereunder shall operate as a waiver thereof nor shall any single or partial exercise of any right or power preclude any other or further exercise of any right or power hereunder.

17. SEVERABILITY

If any one or more of the provisions contained in this Contract or any documents executed in connection herewith shall be invalid, illegal or unenforceable in any respect under any applicable law, the validity, legality and enforceability of the remaining provisions contained herein shall not in any way be affected or impaired.

18. ENTIRE AGREEMENT AND MODIFICATION

This Contract embodies and sets forth the entire agreement and understanding of the Parties and supersedes all prior oral or written agreements, understandings or arrangements relating to the subject matter of this Contract. Neither Party shall be entitled to rely on any agreement, understanding or arrangement which is not expressly set forth in this Contract.

19. NO PARTNERSHIP

Nothing in this Contract shall be deemed to constitute a partnership between the Parties nor constitute one Party the general agent of the other Party. It is hereby expressly agreed and declared that the Contractor shall in the performance of the Works and for all other purposes be deemed to be an independent consultant.

20. SUB-CONTRACT AND ASSIGNMENT

20.1 Subject to Clause 20.3, neither Party shall without the prior written consent of the other Party transfer or assign (legally, equitably or otherwise) all or any of its rights, obligations or benefits hereunder to any third party or parties.

20.2 Without prejudice to Clause 20.1, the Contractor shall be responsible and liable to the Company for all acts, defaults and omissions of (i) any sub-contractor appointed by the Contractor; (ii) any assignee; and (iii) any employees or agents of any subcontractor or assignee, and shall fully indemnify and keep the Company fully indemnified against all loss and damage suffered by the Company arising out of or in connection with such acts, defaults or omissions.

20.3 Notwithstanding Clause 20.1, the Company shall have the sole right and discretion at any time to assign or transfer this Contract whether in whole or in part to any of its subsidiaries or associated companies.

20.4 The Contractor shall not have the right to require the Company to deal or communicate with or make any payment or give any certificate to any agent or attorney of the Contractor. If the Company shall so deal or communicate with or make any payment or give any certificate to any such agent or attorney whether on one occasion or on any number of occasions, the same shall not be or be deemed to be a waiver of the provisions of this Clause 20.4 either as regards any specific agent or attorney or otherwise.

21. COSTS

Each of the Parties shall bear its own legal and other costs and expenses incurred in connection with the negotiation, preparation and execution of this Contract.

22. CONFIDENTIALITY

22.1 The Contractor undertakes:

- (a) to keep confidential all Confidential Information (whether written or oral) which it has obtained or received as a result of the discussions leading up to or the entering into, or obtains or receives in performance of, this Contract;
- (b) not to disclose the Confidential Information in whole or in part to any person without the Company's prior written consent, save to those of its employees or such third parties appointed in the performance of this Contract and who need to know the same and who shall be directed by the Contractor to observe the same obligations of confidentiality with respect thereto;
- (c) to use the Confidential Information solely in connection with the performance of this Contract and not otherwise or for its own benefit; and
- (d) not to write, contribute or publish any article or news or make any presentation or public statement through whatever medium in respect of the Works or this Contract without the prior written approval of the Company.

22.2 The provisions of Clause 22.1 shall not apply to the whole or any part of the Confidential Information which is:

- (a) already in the Contractor's possession which the Contractor can show from written records other than as a result of a breach of Clause 22.1;
- (b) in the public domain other than as a result of a breach of Clause 22.1;
- (c) required to be disclosed pursuant to a statutory obligation or by any court or tribunal; or
- (d) disclosed with prior written consent of the Company.

22.3 The restrictions contained in this Clause 22 shall continue to apply after the termination of this Contract without limit in time.

22.4 Upon termination of this Contract for whatever reason and at all other times when requested to do so by the Company, the Contractor shall deliver up to the Company all copies of Confidential Information (in whatever format) that are its possession.

23. VARIATION

This Contract shall not be altered, amended or modified except by written instruments signed by the Parties.

24. COUNTERPARTS

This Contract may be executed in any number of counterparts, all of which when taken together shall constitute one and the same instrument, and the Parties may execute this Contract by signing on separate counterparts.

25. CONTRACTS (RIGHTS OF THIRD PARTIES) ACT

A person who is not a party to this Agreement shall have no right under the Contracts (Rights of Third Parties) Act (Cap. 53B) to enforce any of its terms.

26 GOVERNING LAW AND JURISDICTION

- 26.1 This Contract shall be governed by and construed in accordance with the laws of the Republic of Singapore.
- 26.2 In respect of any legal action or proceedings arising out of or in connection with this Agreement, the parties irrevocably submit to the jurisdiction of the courts of Singapore.

IN WITNESS WHEREOF the Parties hereto have hereunto set their respective hands the day and year first above written.

SIGNED BY)
DIRECTOR, CORPORATE)
PLANNING & SERVICES)
for and on behalf of)
SINGAPORE ARTS SCHOOL LTD) _____

in the presence of:)
SENIOR MANAGER, OFFICE OF)
VENUE MANAGEMENT) _____

SIGNED BY
(Authorised Representative)
for and on behalf of **[Contractor Name]**
[Name / Designation]) _____
)

in the presence of:)
)
_____) _____
[Name / Designation])

Annex B : SELECTION CRITERIA

SELECTION CRITERIA

- 1.1 Singapore Arts School Limited (the Company) is seeking to enter into a contractual agreement with a Contractor who best addresses the Company's objective to obtain the best value from the Contractor's services. In line with this principle, the Company will adopt the following criteria for the selection of a Contractor.

Tendering for the Replacement of Video Show Relay Systems with Maintenance Services shall be evaluated based on the following criteria:

- ✓ a) Submission of Tender on/before the Tender Closing Date and Time
- ✓ b) Mandatory attendance at the Online Tender Briefing and Site Show
- c) Tenderer compliance to registration with Government Supplier Registration (GSR) Head Registration and Financial Grade:
 - i) **GSR Head** : **Audio Visual, Photographic & Optical Products and Audio Visual Production Services**
EPU/AVP/10
Audio and audio-visual equipment, accessories and supplies, white boards (excludes CATV systems).
Photographic equipment and supplies, including processing services. Optical equipment and supplies, eg films etc.
Photography, video CD production services
 - ii) **Financial Grade** : **S3 and above**
Tendering Capacity up to S\$250,000 and above
- d) Valid certifications before the Tender registration open date. (where applicable)
- e) Compliance with list of required Tender Documents submission (please refer to Schedule 1 - Instruction to Tenderers, Point 1)
- ✓ f) Completeness of Schedule 3, Schedule of Price
 - g) Tender Proposal includes
 - I. ✓ Product Brochures with Technical Specifications of the Proposed Brand and Model
 - II. Detailed installation plan includes cabling works
 - h) Lead time for delivery
- ✓ i) Compliance with points in the Annex C and Annex D- Requirements marked with # are critical specifications that need to be adhered to
- j) Financial capabilities of the Tenderer
- k) Record of past and current contracts/ projects
 - l) Other relevant certifications (if any, such as certification from authorised dealership, service provider, service /repair centre of the proposed brand and models)

- 1.2 The Company is not bound to award to the lowest quotation.

Note: Criteria marked with ✓ are critical.

Annex C : **TECHNICAL REQUIREMENTS**

TO SUPPLY, DELIVER, INSTALL, CONFIGURE, SYNCHRONISE, PROGRAMMING, TESTING AND COMMISSIONING OF VIDEO SHOW RELAY SYSTEMS WITH VIDEO RECORDING CAPABILITY IN CONCERT HALL, DRAMA THEATRE AND STUDIO THEATRE AT SCHOOL OF THE ARTS, SINGAPORE

The Contractor shall inspect and examine each Venue and its surroundings, and to take measurements/ calculations of dimensions of space and distance onsite during the **compulsory site recce, for accuracy of measurements, before submission of quotation and proposal.**

1. TECHNICAL REQUIREMENTS

S/N.	Description
1.1	The proposed Video Show Relay System is to provide Live Video Coverage of Activities at Front of House Foyer areas and the Performing Venues Stages (IR and Non IR) distributed to Multiple Rooms, Stage Monitor Displays and Foyer Late Comers Monitors.
1.2	Digital Video Recorders with Long Recording and Scheduling Capabilities for Archiving Purposes shall be integrated into the proposed systems at each individual venue.
# 1.3	There shall be a Local Singapore Office and/or Service Centre for all proposed Video Show Relay System and its accompanying peripherals.
1.4	A Video feed from Each Venue shall be sent to the Technician’s Office at Level 3 for monitoring purposes.
# 1.5	All proposed systems shall include a compatible fully functional Selectable Toggle, Button Panel or touch panel/screen installed at Stage Manager Control Station for selection of Camera Views on the existing Dual Display Monitors.
1.6	All systems, equipment and peripherals and installation methods proposed must be fully functional and compatible with each other, including the Performing Venues existing video equipment (dual display monitor) and Power Supply Distribution, and infrastructure safety regulation.
1.7	All systems proposed must consider the aesthetic implications of the systems deployment across the Performing Venues ensuring that its effects are minimal.
1.8	The deployment of the cameras and display monitors of the system across the Performing Venues will be based on designated groups each with their own respective uses and requirements. These groups are outlined in the location layout plans and signal flow diagrams in Appendix i - Video Show Relay System Equipment Layout Plan and Appendix ii - Video Show Relay System Block Diagram.
# 1.9	Technical specifications/ brand and model number/ product brochure of the proposed system and equipment, to be submitted together with the submission of the quotation and proposal.
1.10	All cable used, if needed, shall inhere to the following (depending on the type of cable): <ul style="list-style-type: none"> ● 75 Ohm SDI Coax, 18 AWG Solid Bare Copper Conductor with Polyethylene Insulation, Foil + 95% Tinned Copper Braid Shield, PVC Jacket and CMR. ● Cat 6 Ethernet Cable, 4PR x 24 AWG U/UTP Cable, Solid Bare Copper, 24 AWG Solid Copper Conductor pairs and anti-crosstalk divider, with PE insulation and Low Smoke Zero Halogen (Flame retardant) jacket. ● Fibre Optic Cable, LC, duplex, OM 3 Multimode.

2. Equipment Technical Requirements - CONCERT HALL

S/N.	QTY	DESCRIPTION
2.1	3 Units	<p>Network PTZ Camera:</p> <ul style="list-style-type: none"> ● # Must be compatible with proposed Network Switch, Network Video Recorder, Network PTZ camera controller and Control System Software. ● Image Sensor: minimum 1/1.8" progressive scan CMOS or higher ● # Resolution: Minimum of 8MP and Minimum Resolution of 3840 × 2160 ● # Minimum Illumination: Colour: 0.005 Lux or less, B/W: 0.001 Lux or less, 0 Lux with IR ● # Zoom: Minimum 20x optical zoom or more / Minimum 15x digital zoom or more ● Field of View: <ul style="list-style-type: none"> - Horizontal field of view: estimate range of 50° to 3° or equivalent - Vertical field of view: estimate range of 29° to 2° or equivalent - Diagonal field of view: estimate range of 57° to 3° or equivalent ● Supplemental Illumination: IR Minimum of 150m ● PTZ Movement Range: <ul style="list-style-type: none"> - # Pan 360° - # Tilt: Minimum Range of -15° or to 90° with auto flip - Pan speed: Configurable from Minimum Range of 0.1° to 160°/s - Tilt speed: Configurable from Minimum Range of 0.1° to 120°/s ● Video: <ul style="list-style-type: none"> - 50 Hz: At 25 fps (3840 × 2160, 2560 × 1440, 1920 × 1080, 1280 × 960, 1280 × 720) - 60 Hz: At 24fps (3840 × 2160, 2560 × 1440, 1920 × 1080, 1280 × 960, 1280 × 720) ● # Compression: H.265+/H.265/H.264+/H.264 ● Bitrate: estimate range from 32 kbps to 16mbps <ul style="list-style-type: none"> - At 1080p: estimate range of 1mbps to 4mbps ● Image <ul style="list-style-type: none"> - Day/Night Switch, Day, Night, Auto, Schedule - #Image setting: Saturation, brightness, contrast, sharpness, gain, and white balance adjustable by software or web browser ● Audio <ul style="list-style-type: none"> - Compression: G.711 alaw, G.711 ulaw, G.722.1, G.726, MP2L2, AAC, PCM - Bitrate: Minimum of 64 Kbps (G.711)/Minimum of 16 Kbps (G.722.1)/Minimum of 16 Kbps (G.726)/Minimum Range of 32-192 Kbps (MP2L2)/Minimum Range of 16-64 Kbps(AAC) - Sampling Rate: Minimum Range of 8 kHz-48 kHz ● Network <ul style="list-style-type: none"> - Storage NAS (NFS, SMB/CIFS), auto network replenishment (ANR) - Protocols: IPv4/IPv6, HTTP, HTTPS, 802.1x, QoS, FTP, SMTP, UPnP, SNMP, DNS, DDNS, NTP, RTSP, RTCP, RTP, TCP/IP, UDP, IGMP, ICMP, DHCP, PPPoE, Bonjour, Websocket, Websockets - API: Open Network Video Interface (Version 19.12, Profile S, Profile G, Profile T), ISAPI, SDK, ISUP - User/Host: Minimum of 32 users with 3 user levels: administrator, operator, and user - Web Browser IE11, Chrome 57+ ● Security: Password protection, complicated password, HTTPS encryption, 802.1X authentication (EAP-TLS, EAP-LEAP, EAP-MD5), watermark, IP address filter, basic and digest authentication for HTTP/HTTPS, RTP/RTSP over HTTPS, control timeout settings, security audit log, TLS 1.2, TLS 1.3, host authentication (MAC address) ● #Interface: 1 RJ45 10M/100M self-adaptive Ethernet port ● On-board Storage: Built-in memory card slot, support microSD/SDHC/SDXC card of Minimum of 256 GB

S/N.	QTY	DESCRIPTION
2.2	7 Units	<p>Network CCTV Camera:</p> <ul style="list-style-type: none"> ● # Must be compatible with proposed Network Switch, Network Video Recorder, and Control System Software. ● Image Sensor: minimum 1/3" Progressive Scan CMOS or higher ● # Resolution: Minimum of 4MP and Minimum Resolution of 2560 × 1440 ● # Minimum Illumination for Colour: 0.01 Lux or less, B/W: 0 Lux with IR ● Angle Adjustment: Pan: 0° to 360°, tilt: 0° to 90°, rotate: 0° to 360° ● Lens Type: Minimum of 2.8 mm ● Focal Length and Field of View (FOV): Minimum Horizontal FOV 99°, Minimum Vertical FOV 55° and Minimum Diagonal FOV 116° ● Supplemental Illumination, IR up to 30m or more ● Video <ul style="list-style-type: none"> - 50 Hz: At 20 fps (2560 × 1440), At 25 fps (1920 × 1080, 1280 × 720) - 60 Hz: At 20 fps (2560 × 1440), At 24 fps (1920 × 1080, 1280 × 720) - # Compression: H.265+/H.265/H.264+/H.264 - Bitrate: Minimum range of 32 Kbps to 8 Mbps ● Audio <ul style="list-style-type: none"> - G.711ulaw/G.711alaw/G.722.1/G.726/MP2L2/PCM/AAC-LC - Birate: Minimum of 64 Kbps (G.711 ulaw)/64 Kbps (G.711 alaw)/Minimum of of16 Kbps (G.722.1)/Minimum of 16 Kbps (G.726)/Minimum Range of 32 to 160 Kbps (MP2L2)/Minimum Range of 16 to 64 Kbps (AAC-LC) ● Network <ul style="list-style-type: none"> - Security: Password protection, complicated password, watermark, basic and digest authentication for HTTP, WSSE and digest authentication for Open Network Video Interface, security audit log, host authentication (MAC address) - Protocols TCP/IP, ICMP, DHCP, DNS, HTTP, RTP, RTSP, NTP, IGMP, IPv6, UDP, QoS, FTP, SMTP - User/Host: Up to 32 users, 3 levels: administrator, operator, and user ● # Interface: 1 RJ45 10M/100M self-adaptive Ethernet port ● On-board Storage: Built-in memory card slot, support microSD/microSDHC/microSDXC card, Minimum of 256 GB

TECHNICAL REQUIREMENTS

ANNEX C

S/N.	QTY	DESCRIPTION
2.3	1 Unit	<p>Network INFRARED Camera:</p> <ul style="list-style-type: none"> ● # Must be compatible with proposed Network Switch, Network Video Recorder, and Control System Software. ● Image Sensor: minimum 1/3" Progressive Scan CMOS or higher ● # Resolution: Minimum of 4MP, Minimum Resolution of 2560 × 1440 ● Illumination: Colour: 0.005 Lux or less, B/W: 0 Lux with IR ● Lens: Varifocal, Motor-driven, Range of 2.8mm to 12 mm ● Field of View: Minimum Range of 2.8 to 12 mm: Minimum Range of Horizontal FOV 102° to 31°, Minimum Range of Vertical FOV 55° to 18°, Minimum Range of Diagonal FOV 122° to 36° ● Supplemental Illumination, IR up to 50m or more ● Video <ul style="list-style-type: none"> - 50 Hz: 20 fps (2560 × 1440), 25 fps (1920 × 1080, 1280 × 720) - 60 Hz: 20 fps (2560 × 1440), 30 fps (1920 × 1080, 1280 × 720) - # Compression: H.265+/H.265/H.264+/H.264 - Bitrate Minimum Range of 32 Kbps to 8 Mbps ● Audio <ul style="list-style-type: none"> - G.711ulaw/G.711alaw/G.722.1/G.726/MP2L2/PCM/AAC - Bitrate: Minimum of 64 Kbps (G.711)/16 Kbps (G.722.1)/Minimum of 16 Kbps (G.726)/Minimum Range of 32 to 160 Kbps (MP2L2)/Minimum Range of 16 to 64 Kbps (AAC) ● Network <ul style="list-style-type: none"> - Protocols: TCP/IP, ICMP, HTTP, HTTPS, FTP, DHCP, DNS, DDNS, RTP, RTSP, RTCP, NTP, UPnP/PTM, SMTP, IGMP, 802.1X, QoS, IPv6, Bonjour, IPv4, UDP, SSL/TLS - Minimum of 32 users with 3 user levels: administrator, operator, and user ● # Interface: 1 RJ45 10M/100M self-adaptive Ethernet port ● On-Board Storage Built-in memory card slot, support microSD card, up to Minimum of 256 GB
2.4	1 Unit	<p>Network PTZ Camera Controller:</p> <ul style="list-style-type: none"> ● # Compatible with proposed Network PTZ Camera ● # Able to control Zoom, Pan/Tilt and Focus on the proposed Network PTZ Camera ● Interface <ul style="list-style-type: none"> - Minimum of USB Ports 2 × USB 2.0 - Serial Interface Network, RS-232, RS-422, RS-485 - # Interface 10/100/1000 Mbps adaptive ethernet port - WiFi: Supported ● Display: Minimum of 10.1" TFT LCD touchscreen with Minimum Resolution of 1280 × 800 ● Joystick: 4-axis joystick ● Video Output Interface of Minimum Type 1 × HDMI and Minimum 1 × DVI ● Audio Interface <ul style="list-style-type: none"> - Audio Input: 1-ch, 3.5 mm connector - Audio Output: 1-ch, 3.5 mm connector

TECHNICAL REQUIREMENTS

ANNEX C

S/N.	QTY	DESCRIPTION
2.5	1 Unit	<p>Network Video Recorder:</p> <ul style="list-style-type: none"> ● # Able to trigger recording function/schedule by proposed Control System Software. ● # To equip with minimum 20TB HDD for at least 60 days of recording. ● # Capable of exporting the recorded video file to a portable USB flash drive. ● # IP Video Input of Minimum 16 Channels ● HDMI Output 1-ch, 4K (3840 × 2160)/30 Hz, 2K (2560 × 1440)/60 Hz, 1920 × 1080/60 Hz, 1600 × 1200/60 Hz, 1280 × 1024/60 Hz, 1280 × 720/60 Hz, 1024 × 768/60 Hz ● VGA Output 1-ch, 1920 × 1080/60 Hz, 1280 × 1024/60 Hz, 1280 × 720/60 Hz ● Video Output Mode HDMI/VGA independent output ● Audio Output 1-ch, RCA ● Video Decoding <ul style="list-style-type: none"> - # Format H.265/H.265+/H.264+/H.264 - Recording Minimum Resolution Range of 12 MP/8 MP/6 MP/5 MP/4 MP/3 MP/1080p/UXGA/720p/VGA/4CIF/DCIF/2CIF/CIF/QCIF - Synchronous playback 16-ch - Decoding Capability: 2-ch@12 MP (30 fps)/3-ch@8 MP (30 fps)/6-ch@4 MP (30 fps)/12-ch@1080p (30 fps) ● Audio Compression G.711ulaw/G.711alaw/G.722/G.726/AAC ● Network <ul style="list-style-type: none"> - Minimum of Remote 128 Connections - API ONVIF (profile S/G) SDK, ISAPI - Network Protocol TCP/IP, DHCP, IPv4, IPv6, DNS, DDNS, NTP, RTSP, SADP, SMTP, SNMP, NFS, iSCSI, ISUP, UPnP™, HTTP, HTTPS - # 1x RJ-45 10/100/1000 Mbps self-adaptive Ethernet interface ● Auxiliary Interface <ul style="list-style-type: none"> - Minimum of 2 SATA interfaces - Minimum of 10TB capacity for each HDD - Minimum of 2 × USB 2.0

S/N.	QTY	DESCRIPTION
2.6	2 Units	<p>Touchscreen Tablet Controller:</p> <ul style="list-style-type: none"> ● # Compatible with proposed Control System Software and Network Video Recorder. ● # Processor and Graphics <ul style="list-style-type: none"> - Minimum of Intel N200 with UHD Graphics or Equivalent ● # Memory and Storage <ul style="list-style-type: none"> - Minimum of 8GB LPDDR RAM and Minimum of 128GB UFS Storage ● Display <ul style="list-style-type: none"> - Touchscreen: Minimum of 10.5" Display - Minimum Resolution of 1920 × 1280 - Minimum Aspect ratio of 3:2 - Contrast ratio of Minimum 1500:1 - Colour profile: sRGB and Enhanced or Equivalent - Individually colour-calibrated display or Equivalent - #Touch: Minimum of 10-point multi-touch - Brightness: Minimum of 350 nits ● Ports and Connectivity <ul style="list-style-type: none"> - # USB-C 3.1 (Data, DisplayPort and Charging) - MicroSDXC card reader - 3.5mm headphone jack - Minimum WiFi 6: 802.11ax compatible - Minimum Bluetooth Wireless 5.1 - #Come with USB-C with Network port converters ● Software <ul style="list-style-type: none"> - #Preinstalled Operating System of Windows 11 or equivalent. - #Preinstalled Software Control Application for Video Show Relay Switching, Control and Monitoring Functions ● Accessories <ul style="list-style-type: none"> - To include power supply, cables, protective cover, and screen protector. - To include convertors and cables that is needed to connect the Touchscreen Tablet Controller to the Video Show Relay System.
2.7	3 Units	<p>55" Smart TV:</p> <ul style="list-style-type: none"> ● # 55" Screen with Minimum Resolution of 4K 3820 x 2160 @ 60Hz ● # Operating System: Google TV or equivalent. ● # Compatible with the proposed Video Show Relay System. ● # Able to decode and play H.265 video source over AVOIP ● Minimum of Bluetooth 5.1 ● Minimum Wifi 2.4Ghz/5Ghz ● # Wall Mounting: 200mm x 200mm ● Interface and Ports <ul style="list-style-type: none"> - Minimum of 3x HDMI 2.0 ports - HDMI ARC - Minimum of 2x USB 2.0 port - Minimum of 1x AV In port - # 1x RJ-45 10/100/1000 Mbps Ethernet interface ● Accessories <ul style="list-style-type: none"> - To include wall mounting device - To include power supply and necessary cables.

TECHNICAL REQUIREMENTS

ANNEX C

S/N.	QTY	DESCRIPTION
2.8	13 Units	<p>32" Smart TV:</p> <ul style="list-style-type: none"> ● # 32" Screen with Minimum Resolution of 1366 x 768 @ 60Hz ● # Operating System: Google TV ● # Compatible with the proposed Video Show Relay System. ● # Able to decode and play H.265 video source over AVOIP ● Minimum of Bluetooth 5.1 ● Wifi 2.4Ghz/5Ghz ● # Wall Mounting: 200mm x 200mm ● Interface and Ports <ul style="list-style-type: none"> - Minimum of 2x HDMI 1.4 ports - HDMI ARC - Minimum of 2x USB 2.0 ports - Minimum of 1x AV In port - # 1x RJ-45 10/100/1000 Mbps Ethernet interface ● Accessories <ul style="list-style-type: none"> - To include wall mounting device - To include power supply and necessary cables.
2.9	1 Unit	<p>48 Port Network Switch:</p> <ul style="list-style-type: none"> ● # To be compatible with all equipment listed in Video Show Relay System. ● # 1 Unit, 1U Rack Mounted ● # 48-port 1G PoE+(RJ45) ● # Minimum of 2-ports x 10GBASE-T (RJ45) independent stackable managed switch ● Minimum of 2-port x 10GBASE-X (SFP+) independent-stackable managed switch ● #Minimum of 176 Gbps Non-blocking switching fabric across all ports ● Full L3 Feature set and non-stop forwarding (NSF) stacking ● Mini-USB and RJ45 RS232 console ports and USB storage port ● Management: Out-of-band Web GUI; HTTPs; CLI; Telnet; SSH SNMP, MIBs RSPAN Radius Users, TACACS+ ● # IPv4/IPv6 Multicast filtering: IGMPv3 MLDv2 Snooping, Proxy ASM & SSM IGMPv1,v2 Querier (compatible v3) Control Packet Flooding ● IPv4 / IPv6 Policing and Convergence: Auto-VoIP Auto-iSCSI Policy-based routing (PBR) LLDP-MED IEEE 1588 PTPv2 1-Step End to-End Transparent Clock ● VLANs: Static, Dynamic, Voice, MAC GVRP/ GMRP Double VLAN mode Private VLANs ● Trunking Port Channel: Distributed LAG across the stack Static or Dynamic LACP (LACP automatically reverts to and from Static LAG) Seven (7) L2/ L3/L4 hashing algorithms ● IPv4/IPv6 Authentication Security: Successive Tiering (DOT1X; MAB; Captive Portal) DHCP Snooping Dynamic ARP Inspection IP Source Guard ● IPv4/IPv6 Static Routing: Port, Subnet, VLAN routing, DHCP Relay; Multicast static routes; Stateful DHCPv6 Server ● IPv4/IPv6 Dynamic Routing: IPv4: RIP, VRRP IPv4/IPv6: OSPF, Proxy ARP, PIM-SM, PIM-DM, 6-to-4 tunnels ● Accessories <ul style="list-style-type: none"> - To include mounting brackets to mount on Show Relay Video Equipment Rack - To include power supply and necessary cables.

S/N.	QTY	DESCRIPTION
2.10	1 Unit	<p>8 Port Network Switch:</p> <ul style="list-style-type: none"> ● # To be compatible with all equipment listed in Video Show Relay System. ● #8-port 10/100/1000BASE-T (RJ45) PoE+ with 110W PoE ● #Minimum of 1-port x 10/100/1000BASE-T (RJ45) ● #Minimum of 1-port x 1000BASE-X (SFP) ● #20 Gbps non-blocking fabric across 10 ports ● USB-C console port and USB-A storage port ● Management: Out-of-band ITWeb GUI (main) HTTPs CLI; Telnet; SSH SNMP, MIBs RSPAN Radius Users, TACACS+ ● #IPv4 / IPv6 Multicast Filtering: IGMPv3 MLDv2 Snooping, Proxy ASM & SSM IGMPv1,v2 Querier (compatible v3) Control Packet Flooding ● IPv4 / IPv6 Policing and Convergence: Policy-based routing (PBR) LLDP-MED IEEE 1588 PTPv2 1-Step End-to-End Transparent Clock ● VLANs: Static, Dynamic, Voice, MAC GVRP/ GMRP Double VLAN mode Private VLANs ● Trunking Port Channel: Auto-Trunk and Auto-LAG between M4250 Switches Static LAG, or Dynamic LACP (LACP automatically reverts to and from Static LAG) Seven (7)L2/ L3/L4 hashing algorithms ● IPv4 / IPv6 Authentication Security: Successive Tiering (DOT1X; MAB; Captive Portal) DHCP Snooping Dynamic ARP Inspection IP Source Guard ● IPv4 / IPv6 Static Routing: Port, Subnet, VLAN routing Multicast static routes DHCPv4 Server DHCP Relay Stateful DHCPv6 Server ● IPv4 / IPv6 Dynamic Routing: IPv4: RIP IPv4/IPv6: PIM-SM PIM-DM SSM ● To include mounting brackets to mount on Show Relay Video Equipment Rack ● Accessories <ul style="list-style-type: none"> - To include mounting brackets to mount on Show Relay Video Equipment Rack - To include power supply and necessary cables.
2.11	2 Units	<p>AVOIP Media Processor Workstation:</p> <ul style="list-style-type: none"> ● #Pre-Installed Operating System, Window 11 or equivalent ● #Pre-Installed Control System Software application (Please Refer to Control System Software Requirements) ● #Minimum of Ultra Processor 155H with Arc GPU or Equivalent ● #Minimum of 8Gb DDR5 Ram or more ● Minimum of 1 TB SSD or more ● Connectivity <ul style="list-style-type: none"> - Minimum of 1 HDMI 2.1 - Minimum of 1 USB Type-C ports - #Minimum of 2.5GbE (i226-V) / 10GbE (AQC113) LAN - Minimum of Wi-Fi 6E AX1690i, 802.11ax 2x2 3.0Gbps w/ 6GHz + Bluetooth 5.1 - Minimum of 2 USB 3.2 Gen2 Type-A connectors ● Accessories <ul style="list-style-type: none"> - To include mounting brackets, tray, and/or holder to mount unit on to Show Relay Video Equipment Rack. - To include power supply and necessary cables.

S/N.	QTY	DESCRIPTION
2.12	4 Units	<p>IP Media Decoder:</p> <ul style="list-style-type: none"> ● # To be compatible with Venues Dual Display Monitor and proposed HDMI to SDI converter. ● Video Output Resolution Minimum Range: 480i, 480p, 576i, 576p, 720p, 1080i, 1080p60, 2160p60 10-bit (4Kp60) HDR10+ and HLG ● #Video Codecs: AV1, HEVC/H.265, AVC/H.264 (MPEG-4, Part 10), MPEG-2, VP9 ● Audio Codecs: Dolby Digital, Dolby Digital Plus, LC-ACC & HE-AAC ● IP Streaming Format: RTSP, HLS, LL-HLS, Dash, LL- Dash, SRT, HTML5 Video-Tag ● Networking: IGMPv2 / IGMPv3 UDP-Multicast, UDP-Unicast ● Connectivity: <ul style="list-style-type: none"> - #Minimum of 1 HDMI 2.1 - Minimum of 2 USB 2.0 - Minimum of 1 RS232 - #1x RJ-45 10/100/1000 Mbps Ethernet interface ● Accessories <ul style="list-style-type: none"> - To include power supply and necessary cables.
2.13	4 Units	<p>HDMI to SDI Converter:</p> <ul style="list-style-type: none"> ● # To be compatible with Venues Dual Display Monitor and proposed IP Media Decoder. ● #Minimum of 1 SDI and 1 HDMI 2.0 Video Output ● #Minimum of 1 SDI and 1 HDMI 2.0 Video Input ● Auto detection of SD, HD or 6G-SDI ● HDMI Video Standards: 625i50 PAL, 525i29.97 NTSC, 720p50, 720p59.94, 720p60, 1080p23.98, 1080p24, 1080p25, 1080p29.97, 1080p30, 1080p50, 1080p59.94, 1080p60, 1080i50, 1080i59.94, 1080i60, 2160p23.98, 2160p24, 2160p25, 2160p29.97, 2160p30 ● SDI Compliance: SMPTE 259M, SMPTE 292M, SMPTE 296M, SMPTE 372M, SMPTE 424M, SMPTE 425M, SMPTE ST-2081, ITU-R BT.656 and ITU-R BT.601 ● HD Video Standards: 720p50, 720p59.94, 720p60, 1080p23.98, 1080p24, 1080p25, 1080p29.97, 1080p30, 1080p50, 1080p59.94, 1080p60, 1080i50, 1080i59.94, 1080i60 ● Accessories <ul style="list-style-type: none"> - To include power supply and necessary cables.
2.14	1 Unit	<p>Stage Manager Control Desk:</p> <ul style="list-style-type: none"> ● #Material: Sheet Metal Steel ● #Caster Wheel with lock ● To include a put-out drawer ● To include a pair of mounted power point ● To include 2 x XLR Male point and 2 x XLR Female point ● Cable access hole at bottom of the Control Desk ● To include 7U or more rack space ● Must be able to accommodate to our current equipment (Paging system, Audio Relay Control and Dual Display monitor) and vendor proposed equipment ● Dimension: refer to Appendix iii - Technical specification for Stage Manager Control Desk ● Design is not drawn to scale, Vendor is required to take measurements, and able to propose, customize and build according to safety guidelines and user ergonomics ● Please refer to Appendix iii - Technical specification for Stage Manager Control Desk for details.

3. Equipment Technical Requirements – DRAMA THEATRE

S/N.	QTY	DESCRIPTION
3.1	2 Units	<p>Network PTZ Camera:</p> <ul style="list-style-type: none"> ● # Must be compatible with proposed Network Switch, Network Video Recorder, Network PTZ camera controller and Control System Software. ● Image Sensor: minimum 1/1.8" progressive scan CMOS or higher ● #Resolution: Minimum of 8MP and Minimum Resolution of 3840 × 2160 ● #Minimum Illumination: Colour: 0.005 Lux or less, B/W: 0.001 Lux or less, 0 Lux with IR ● #Zoom: Minimum of 20x optical zoom or more / Minimum of 15x digital zoom or more ● Field of View: <ul style="list-style-type: none"> - Horizontal field of view: estimate range of 50° to 3° or equivalent - Vertical field of view: estimate range of 29° to 2° or equivalent - Diagonal field of view: estimate range of 57° to 3° or equivalent ● Supplemental Illumination: IR Minimum of 150m ● PTZ Movement Range: <ul style="list-style-type: none"> - #Pan 360° - #Tilt: Minimum Range of -15° or to 90° with auto flip - Pan speed: Configurable from Minimum Range of 0.1° to 160°/s - Tilt speed: Configurable from Minimum Range of 0.1° to 120°/s ● Video: <ul style="list-style-type: none"> - 50 Hz: At 25 fps (3840 × 2160, 2560 × 1440, 1920 × 1080, 1280 × 960, 1280 × 720) - 60 Hz: At 24fps (3840 × 2160, 2560 × 1440, 1920 × 1080, 1280 × 960, 1280 × 720) ● #Compression: H.265+/H.265/H.264+/H.264 ● Bitrate: estimate range from 32 kbps to 16mbps <ul style="list-style-type: none"> - At 1080p: estimate range of 1mbps to 4mbps ● Image <ul style="list-style-type: none"> - Day/Night Switch, Day, Night, Auto, Schedule - #Image setting: Saturation, brightness, contrast, sharpness, gain, and white balance adjustable by software or web browser ● Audio <ul style="list-style-type: none"> - Compression: G.711 alaw, G.711 ulaw, G.722.1, G.726, MP2L2, AAC, PCM - Bitrate: Minimum of 64 Kbps (G.711)/Minimum of 16 Kbps (G.722.1)/Minimum of 16 Kbps (G.726)/Minimum Range of 32-192 Kbps (MP2L2)/Minimum Range of 16-64 Kbps(AAC) - Sampling Rate: Minimum Range of 8 kHz-48 kHz ● Network <ul style="list-style-type: none"> - Storage NAS (NFS, SMB/CIFS), auto network replenishment (ANR) - Protocols: IPv4/IPv6, HTTP, HTTPS, 802.1x, QoS, FTP, SMTP, UPnP, SNMP, DNS, DDNS, NTP, RTSP, RTP, TCP/IP, UDP, IGMP, ICMP, DHCP, PPPoE, Bonjour, Websocket, Websockets - API: Open Network Video Interface (Version 19.12, Profile S, Profile G, Profile T), ISAPI, SDK, ISUP - User/Host: Minimum of 32 users with 3 user levels: administrator, operator, and user - Web Browser IE11, Chrome 57+ ● Security: Password protection, complicated password, HTTPS encryption, 802.1X authentication (EAP-TLS, EAP-LEAP, EAP-MD5), watermark, IP address filter, basic and digest authentication for HTTP/HTTPS, RTP/RTSP over HTTPS, control timeout settings, security audit log, TLS 1.2, TLS 1.3, host authentication (MAC address) ● #Interface: 1 RJ45 10M/100M self-adaptive Ethernet port ● On-board Storage: Built-in memory card slot, support microSD/SDHC/SDXC card of Minimum of 256 GB

TECHNICAL REQUIREMENTS

ANNEX C

S/N.	QTY	DESCRIPTION
3.2	6 Units	<p>Network CCTV Camera:</p> <ul style="list-style-type: none"> ● # Must be compatible with proposed Network Switch, Network Video Recorder, and Control System Software. ● Image Sensor: minimum 1/3" Progressive Scan CMOS or higher ● #Resolution: #Minimum of 4MP and Minimum Resolution of 2560 × 1440 ● #Minimum Illumination for Colour: 0.01 Lux or less, B/W: 0 Lux with IR ● Angle Adjustment: Pan: 0° to 360°, tilt: 0° to 90°, rotate: 0° to 360° ● Lens Type: Minimum of 2.8 mm ● Focal Length and Field of View (FOV): Minimum Horizontal FOV 99°, Minimum Vertical FOV 55° and Minimum Diagonal FOV 116° ● Supplemental Illumination, IR up to 30m or more ● Video <ul style="list-style-type: none"> - 50 Hz: At 20 fps (2560 × 1440), At 25 fps (1920 × 1080, 1280 × 720) - 60 Hz:-At 20 fps (2560 × 1440), At 24 fps (1920 × 1080, 1280 × 720) - #Compression: H.265+/H.265/H.264+/H.264 - Bitrate: Minimum range of 32 Kbps to 8 Mbps ● Audio <ul style="list-style-type: none"> - G.711ulaw/G.711alaw/G.722.1/G.726/MP2L2/PCM/AAC-LC - Birate: Minimum of 64 Kbps (G.711 ulaw)/64 Kbps (G.711 alaw)/Minimum of of16 Kbps (G.722.1)/Minimum of 16 Kbps (G.726)/Minimum Range of 32 to 160 Kbps (MP2L2)/Minimum Range of 16 to 64 Kbps (AAC-LC) ● Network <ul style="list-style-type: none"> - Security: Password protection, complicated password, watermark, basic and digest authentication for HTTP, WSSE and digest authentication for Open Network Video Interface, security audit log, host authentication (MAC address) - Protocols TCP/IP, ICMP, DHCP, DNS, HTTP, RTP, RTSP, NTP, IGMP, IPv6, UDP, QoS, FTP, SMTP - User/Host: Up to 32 users, 3 levels: administrator, operator, and user ● #Interface: 1 RJ45 10M/100M self-adaptive Ethernet port ● On-board Storage: Built-in memory card slot, support microSD/microSDHC/microSDXC card, Minimum of 256 GB

TECHNICAL REQUIREMENTS

ANNEX C

S/N.	QTY	DESCRIPTION
3.3	1 Unit	<p>Network INFRARED Camera:</p> <ul style="list-style-type: none"> ● # Must be compatible with proposed Network Switch, Network Video Recorder, and Control System Software. ● Image Sensor: minimum 1/3" Progressive Scan CMOS or higher ● #Resolution: Minimum of 4MP, Minimum Resolution of 2560 × 1440 ● Illumination: Colour: 0.005 Lux or less, B/W: 0 Lux with IR ● Lens: Varifocal, Motor-driven, Range of 2.8mm to 12 mm ● Field of View: Minimum Range of 2.8 to 12 mm: Minimum Range of Horizontal FOV 102° to 31°, Minimum Range of Vertical FOV 55° to 18°, Minimum Range of Diagonal FOV 122° to 36° ● Supplemental Illumination, IR up to 50m or more ● Video <ul style="list-style-type: none"> - 50 Hz: 20 fps (2560 × 1440), 25 fps (1920 × 1080, 1280 × 720) - 60 Hz: 20 fps (2560 × 1440), 30 fps (1920 × 1080, 1280 × 720) - #Compression: H.265+/H.265/H.264+/H.264 - Bitrate Minimum Range of 32 Kbps to 8 Mbps ● Audio <ul style="list-style-type: none"> - G.711ulaw/G.711alaw/G.722.1/G.726/MP2L2/PCM/AAC - Bitrate: Minimum of 64 Kbps (G.711)/16 Kbps (G.722.1)/Minimum of 16 Kbps (G.726)/Minimum Range of 32 to 160 Kbps (MP2L2)/Minimum Range of 16 to 64 Kbps (AAC) ● Network <ul style="list-style-type: none"> - Protocols: TCP/IP, ICMP, HTTP, HTTPS, FTP, DHCP, DNS, DDNS, RTP, RTSP, RTCP, NTP, UPnP, SMTP, IGMP, 802.1X, QoS, IPv6, Bonjour, IPv4, UDP, SSL/TLS - Minimum of 32 users with 3 user levels: administrator, operator, and user ● #Interface: 1 RJ45 10M/100M self-adaptive Ethernet port ● On-Board Storage Built-in memory card slot, support microSD card, up to Minimum of 256 GB
3.4	1 Unit	<p>Network PTZ Camera Controller:</p> <ul style="list-style-type: none"> ● Compatible with proposed Network PTZ Camera ● Interface <ul style="list-style-type: none"> - Minimum of USB Ports 2 × USB 2.0 - Serial Interface Network, RS-232, RS-422, RS-485 - #Interface 10/100/1000 Mbps adaptive ethernet port; - WiFi: Supported ● Display: Minimum of 10.1" TFT LCD touchscreen with Minimum Resolution of 1280 × 800 ● Joystick: 4-axis joystick ● Video Output Interface of Minimum Type 1 × HDMI and Minimum 1 × DVI ● Audio Interface <ul style="list-style-type: none"> - Audio Input: 1-ch, 3.5 mm connector - Audio Output: 1-ch, 3.5 mm connector

TECHNICAL REQUIREMENTS

ANNEX C

S/N.	QTY	DESCRIPTION
3.5	1 Unit	<p>Network Video Recorder:</p> <ul style="list-style-type: none"> ● # To be able to trigger recording function/schedule by proposed Control System Software. ● # To equip with minimum 20TB HDD for at least 60 days of recording. ● # Capable of exporting the recorded video file to a portable USB flash drive. ● #IP Video Input of Minimum 16 Channels ● HDMI Output 1-ch, 4K (3840 × 2160)/30 Hz, 2K (2560 × 1440)/60 Hz, 1920 × 1080/60 Hz, 1600 × 1200/60 Hz, 1280 × 1024/60 Hz, 1280 × 720/60 Hz, 1024 × 768/60 Hz ● VGA Output 1-ch, 1920 × 1080/60 Hz, 1280 × 1024/60 Hz, 1280 × 720/60 Hz ● Video Output Mode HDMI/VGA independent output ● Audio Output 1-ch, RCA ● Video Decoding <ul style="list-style-type: none"> - #Format H.265/H.265+/H.264+/H.264 - Recording Minimum Resolution Range of 12 MP/8 MP/6 MP/5 MP/4 MP/3 MP/1080p/UXGA/720p/VGA/4CIF/DCIF/2CIF/CIF/QCIF - Synchronous playback 16-ch - Decoding Capability: 2-ch@12 MP (30 fps)/3-ch@8 MP (30 fps)/6-ch@4 MP (30 fps)/12-ch@1080p (30 fps) ● Audio Compression G.711ulaw/G.711alaw/G.722/G.726/AAC ● Network <ul style="list-style-type: none"> - Minimum of Remote 128 Connections - API ONVIF (profile S/G) SDK, ISAPI - Network Protocol TCP/IP, DHCP, IPv4, IPv6, DNS, DDNS, NTP, RTSP, SADP, SMTP, SNMP, NFS, iSCSI, ISUP, UPnP™, HTTP, HTTPS - #1x RJ-45 10/100/1000 Mbps self-adaptive Ethernet interface ● Auxiliary Interface <ul style="list-style-type: none"> - Minimum of 2 SATA interfaces - Minimum of 10TB capacity for each HDD - Minimum of 2 × USB 2.0

TECHNICAL REQUIREMENTS

ANNEX C

S/N.	QTY	DESCRIPTION
3.6	2 Units	<p>Touchscreen Tablet Controller:</p> <ul style="list-style-type: none"> ● #Processor and Graphics <ul style="list-style-type: none"> - Minimum of Intel N200 with UHD Graphics or Equivalent ● #Memory and Storage <ul style="list-style-type: none"> - Minimum of 8GB LPDDR RAM and Minimum of 128GB UFS Storage ● Display <ul style="list-style-type: none"> - Touchscreen: Minimum of 10.5" Display - Minimum Resolution of 1920 × 1280 - Minimum Aspect ratio of 3:2 - Contrast ratio of Minimum 1500:1 - Colour profile: sRGB and Enhanced or Equivalent - Individually colour-calibrated display or Equivalent - #Touch: Minimum of 10-point multi-touch - Brightness: Minimum of 350 nits ● Ports and Connectivity <ul style="list-style-type: none"> - #USB-C 3.1 (Data, DisplayPort and Charging) - MicroSDXC card reader - 3.5mm headphone jack - Minimum WiFi 6: 802.11ax compatible - Minimum Bluetooth Wireless 5.1 - #Come with USB-C with Network port converters ● Software <ul style="list-style-type: none"> - #Preinstalled Operating System of Windows 11 or equivalent - #Preinstalled Software Control Application for Video Show Relay Switching, Control and Monitoring Functions ● Accessories <ul style="list-style-type: none"> - To include power supply, cables, protective cover, and screen protector. - To include convertors and cables that is needed to connect touchscreen tablet controller to the Video Show Relay System.
3.7	3 Units	<p>55" Smart TV:</p> <ul style="list-style-type: none"> ● #55" Screen with Minimum Resolution of 4K 3820 x 2160 @ 60Hz ● #Operating System: Google TV or equivalent. ● #Compatible with the proposed Video Show Relay System. ● #Able to output H.265 video source over AVOIP without external convertor ● Minimum of Bluetooth 5.1 ● Minimum Wifi 2.4Ghz/5Ghz ● #Wall Mounting: 200mm x 200mm ● Interface and Ports <ul style="list-style-type: none"> - Minimum of 3x HDMI 2.0 ports - HDMI ARC - Minimum of 2x USB 2.0 port - Minimum of 1x AV In port - #1x RJ-45 10/100/1000 Mbps Ethernet interface ● Accessories <ul style="list-style-type: none"> - To include wall mounting device - To include power supply and necessary cables.

TECHNICAL REQUIREMENTS

ANNEX C

S/N.	QTY	DESCRIPTION
3.8	14 Units	<p>32" Smart TV:</p> <ul style="list-style-type: none"> ● #32" Screen with Minimum Resolution of 1366 x 768 @ 60Hz ● #Operating System: Google TV ● #Compatible with the proposed Video Show Relay System. ● #Able to output H.265 video source over AVOIP without external convertor ● Minimum of Bluetooth 5.1 ● Wifi 2.4Ghz/5Ghz ● #Wall Mounting: 200mm x 200mm ● Interface and Ports <ul style="list-style-type: none"> - Minimum of 2x HDMI 1.4 ports - HDMI ARC - Minimum of 2x USB 2.0 ports - Minimum of 1x AV In port - #1x RJ-45 10/100/1000 Mbps Ethernet interface ● Accessories <ul style="list-style-type: none"> - To include wall mounting device - To include power supply and necessary cables.
3.9	1 Unit	<p>48 Port Network Switch:</p> <ul style="list-style-type: none"> ● # To be compatible with all equipment listed in Video Show Relay System. ● #1 Unit, 1U Rack Mounted ● #48-port 1G PoE+(RJ45) ● #Minimum of 2-ports x 10GBASE-T (RJ45) independent stackable managed switch ● Minimum of 2-port x 10GBASE-X (SFP+) independent-stackable managed switch ● #Minimum of 176 Gbps Non-blocking switching fabric across all ports ● Full L3 Feature set and non-stop forwarding (NSF) stacking ● Mini-USB and RJ45 RS232 console ports and USB storage port ● Management: Out-of-band Web GUI; HTTPs; CLI; Telnet; SSH SNMP, MIBs RSPAN Radius Users, TACACS+ ● #IPv4/IPv6 Multicast filtering: IGMPv3 MLDv2 Snooping, Proxy ASM & SSM IGMPv1,v2 Querier (compatible v3) Control Packet Flooding ● IPv4 / IPv6 Policing and Convergence: Auto-VoIP Auto-iSCSI Policy-based routing (PBR) LLDP-MED IEEE 1588 PTPv2 1-Step End to-End Transparent Clock ● VLANs: Static, Dynamic, Voice, MAC GVRP/ GMRP Double VLAN mode Private VLANs ● Trunking Port Channel: Distributed LAG across the stack Static or Dynamic LACP (LACP automatically reverts to and from Static LAG) Seven (7) L2/ L3/L4 hashing algorithms ● IPv4/IPv6 Authentication Security: Successive Tiering (DOT1X; MAB; Captive Portal) DHCP Snooping Dynamic ARP Inspection IP Source Guard ● IPv4/IPv6 Static Routing: Port, Subnet, VLAN routing, DHCP Relay; Multicast static routes; Stateful DHCPv6 Server ● IPv4/IPv6 Dynamic Routing: IPv4: RIP, VRRP IPv4/IPv6: OSPF, Proxy ARP, PIM-SM, PIM-DM, 6-to-4 tunnels ● Accessories <ul style="list-style-type: none"> - To include mounting brackets to mount on Show Relay Video Equipment Rack - To include power supply and necessary cables.

TECHNICAL REQUIREMENTS

ANNEX C

S/N.	QTY	DESCRIPTION
3.10	1 Unit	<p>8 Port Network Switch:</p> <ul style="list-style-type: none"> ● # To be compatible with all equipment listed in Video Show Relay System. ● Mounting brackets for flanges on sides ● #8-port 10/100/1000BASE-T (RJ45) PoE+ with 110W PoE ● Minimum of 1-port x 10/100/1000BASE-T (RJ45) ● Minimum of 1-port x 1000BASE-X (SFP) ● #20 Gbps non-blocking fabric across 10 ports ● USB-C console port and USB-A storage port ● Management: Out-of-band ITWeb GUI (main) HTTPs CLI; Telnet; SSH SNMP, MIBs RSPAN Radius Users, TACACS+ ● IPv4 / IPv6 Multicast Filtering: IGMPv3 MLDv2 Snooping, Proxy ASM & SSM IGMPv1,v2 Querier (compatible v3) Control Packet Flooding ● IPv4 / IPv6 Policing and Convergence: Policy-based routing (PBR) LLDP-MED IEEE 1588 PTPv2 1-Step End-to-End Transparent Clock ● VLANs: Static, Dynamic, Voice, MAC GVRP/ GMRP Double VLAN mode Private VLANs ● Trunking Port Channel: Auto-Trunk and Auto-LAG between M4250 Switches Static LAG, or Dynamic LACP (LACP automatically reverts to and from Static LAG) Seven (7)L2/ L3/L4 hashing algorithms ● IPv4 / IPv6 Authentication Security: Successive Tiering (DOT1X; MAB; Captive Portal) DHCP Snooping Dynamic ARP Inspection IP Source Guard ● IPv4 / IPv6 Static Routing: Port, Subnet, VLAN routing Multicast static routes DHCPv4 Server DHCP Relay Stateful DHCPv6 Server ● IPv4 / IPv6 Dynamic Routing: IPv4: RIP IPv4/IPv6: PIM-SM PIM-DM SSM Accessories <ul style="list-style-type: none"> - To include mounting brackets to mount on Show Relay Video Equipment Rack - To include power supply and necessary cables.
3.11	1 Unit	<p>AVOIP Media Processor Workstation:</p> <ul style="list-style-type: none"> ● #Pre-Installed Operating System, Window 11 or equivalent ● #Pre-Installed Control System Software application (Please Refer to Control System Software Requirements) ● #Minimum of Ultra Processor 155H with Arc GPU or Equivalent ● #Minimum of 8Gb DDR5 Ram or more ● Minimum of 1 TB SSD or more ● Connectivity <ul style="list-style-type: none"> - Minimum of 1 HDMI 2.1 - Minimum of 1 USB Type-C ports - #Minimum of 2.5GbE (i226-V) / 10GbE (AQC113) LAN - Minimum of Wi-Fi 6E AX1690i, 802.11ax 2x2 3.0Gbps w/ 6GHz + Bluetooth 5.1 - Minimum of 2 USB 3.2 Gen2 Type-A connectors ● Accessories <ul style="list-style-type: none"> - To include mounting brackets, tray, and/or holder to mount unit on to Show Relay Video Equipment Rack. - To include power supply and necessary cables.

TECHNICAL REQUIREMENTS

ANNEX C

3.12	4 Units	<p>IP Media Decoder:</p> <ul style="list-style-type: none"> ● # To be compatible with Venues Dual Display Monitor and proposed HDMI to SDI converter. ● Video Output Resolution Minimum Range: 480i, 480p, 576i, 576p, 720p, 1080i, 1080p60, 2160p60 10-bit (4Kp60) HDR10+ and HLG ● #Video Codecs: AV1, HEVC/H.265, AVC/H.264 (MPEG-4, Part 10), MPEG-2, VP9 ● Audio Codecs: Dolby Digital, Dolby Digital Plus, LC-ACC & HE-AAC ● IP Streaming Format: RTSP, HLS, LL-HLS, Dash, LL- Dash, SRT, HTML5 Video-Tag ● Networking: IGMPv2 / IGMPv3 UDP-Multicast, UDP-Unicast ● Connectivity: <ul style="list-style-type: none"> - #Minimum of 1 HDMI 2.1 - Minimum of 2 USB 2.0 - Minimum of 1 RS232 - #1x RJ-45 10/100/1000 Mbps Ethernet interface ● Accessories <ul style="list-style-type: none"> - To include power supply and necessary cables.
3.13	4 Units	<p>HDMI to SDI Converter:</p> <ul style="list-style-type: none"> ● # To be compatible with Venues Dual Display Monitor and proposed IP Media Decoder. ● #Minimum of 1 SDI and 1 HDMI 2.0 Video Output ● #Minimum of 1 SDI and 1 HDMI 2.0 Video Input ● Auto detection of SD, HD or 6G-SDI ● HDMI Video Standards: 625i50 PAL, 525i29.97 NTSC, 720p50, 720p59.94, 720p60, 1080p23.98, 1080p24, 1080p25, 1080p29.97, 1080p30, 1080p50, 1080p59.94, 1080p60, 1080i50, 1080i59.94, 1080i60, 2160p23.98, 2160p24, 2160p25, 2160p29.97, 2160p30 ● SDI Compliance: SMPTE 259M, SMPTE 292M, SMPTE 296M, SMPTE 372M, SMPTE 424M, SMPTE 425M, SMPTE ST-2081, ITU-R BT.656 and ITU-R BT.601 ● HD Video Standards: 720p50, 720p59.94, 720p60, 1080p23.98, 1080p24, 1080p25, 1080p29.97, 1080p30, 1080p50, 1080p59.94, 1080p60, 1080i50, 1080i59.94, 1080i60 ● Accessories <ul style="list-style-type: none"> - To include power supply and necessary cables.
3.14	1 Unit	<p>Stage Manager Control Desk:</p> <ul style="list-style-type: none"> ● #Material: Sheet Metal Steel ● #Caster Wheel with lock ● To include a put-out drawer ● To include a pair of mounted power point ● To include 2 x XLR Male point and 2 x XLR Female point ● Cable access hole at bottom of the Control Desk ● To include 7U or more rack space ● Must be able to accommodate to our current equipment (Paging system, Audio Relay Control and Dual Display monitor) and vendor proposed equipment ● Dimension: refer to Appendix iii - Technical specification for Stage Manager Control Desk ● Design is not drawn to scale, Vendor is required to take measurements, and able to propose, customize and build according to safety guidelines and user ergonomics ● Please refer to Appendix iii - Technical specification for Stage Manager Control Desk for details.

4. Equipment Technical Requirements - STUDIO THEATRE

S/N.	QTY	DESCRIPTION
4.1	1 Unit	<p>Network PTZ Camera:</p> <ul style="list-style-type: none"> ● # Must be compatible with proposed Network Switch, Network Video Recorder, Network PTZ camera controller and Control System Software. ● Image Sensor: minimum 1/1.8" progressive scan CMOS or higher ● #Resolution: Minimum of 8MP and Minimum Resolution of 3840 × 2160 ● #Minimum Illumination: Colour: 0.005 Lux or less, B/W: 0.001 Lux or less, 0 Lux with IR ● #Zoom: Minimum of 20x optical zoom or more / Minimum of 15x digital zoom or more ● Field of View: <ul style="list-style-type: none"> - Horizontal field of view: estimate range of 50° to 3° or equivalent - Vertical field of view: estimate range of 29° to 2° or equivalent - Diagonal field of view: estimate range of 57° to 3° or equivalent ● Supplemental Illumination: IR Minimum of 150m ● PTZ Movement Range: <ul style="list-style-type: none"> - #Pan 360° - #Tilt: Minimum Range of -15° or to 90° with auto flip - Pan speed: Configurable from Minimum Range of 0.1° to 160°/s - Tilt speed: Configurable from Minimum Range of 0.1° to 120°/s ● Video: <ul style="list-style-type: none"> - 50 Hz: At 25 fps (3840 × 2160, 2560 × 1440, 1920 × 1080, 1280 × 960, 1280 × 720) - 60 Hz: At 24fps (3840 × 2160, 2560 × 1440, 1920 × 1080, 1280 × 960, 1280 × 720) ● #Compression: H.265+/H.265/H.264+/H.264 ● Bitrate: estimate range from 32 kbps to 16mbps <ul style="list-style-type: none"> - At 1080p: estimate range of 1mbps to 4mbps ● Image <ul style="list-style-type: none"> - Day/Night Switch, Day, Night, Auto, Schedule - #Image setting: Saturation, brightness, contrast, sharpness, gain, and white balance adjustable by software or web browser ● Audio <ul style="list-style-type: none"> - Compression: G.711 alaw, G.711 ulaw, G.722.1, G.726, MP2L2, AAC, PCM - Bitrate: Minimum of 64 Kbps (G.711)/Minimum of 16 Kbps (G.722.1)/Minimum of 16 Kbps (G.726)/Minimum Range of 32-192 Kbps (MP2L2)/Minimum Range of 16-64 Kbps(AAC) - Sampling Rate: Minimum Range of 8 kHz-48 kHz ● Network <ul style="list-style-type: none"> - Storage NAS (NFS, SMB/CIFS), auto network replenishment (ANR) - Protocols: IPv4/IPv6, HTTP, HTTPS, 802.1x, QoS, FTP, SMTP, UPnP, SNMP, DNS, DDNS, NTP, RTSP, RTCP, RTP, TCP/IP, UDP, IGMP, ICMP, DHCP, PPPoE, Bonjour, Websocket, Websockets - API: Open Network Video Interface (Version 19.12, Profile S, Profile G, Profile T), ISAPI, SDK, ISUP - User/Host: Minimum of 32 users with 3 user levels: administrator, operator, and user - Web Browser IE11, Chrome 57+ ● Security: Password protection, complicated password, HTTPS encryption, 802.1X authentication (EAP-TLS, EAP-LEAP, EAP-MD5), watermark, IP address filter, basic and digest authentication for HTTP/HTTPS, RTP/RTSP over HTTPS, control timeout settings, security audit log, TLS 1.2, TLS 1.3, host authentication (MAC address) ● #Interface: 1 RJ45 10M/100M self-adaptive Ethernet port ● On-board Storage: Built-in memory card slot, support microSD/SDHC/SDXC card of Minimum of 256 GB

TECHNICAL REQUIREMENTS

ANNEX C

S/N.	QTY	DESCRIPTION
4.2	4 Units	<p>Network CCTV Camera:</p> <ul style="list-style-type: none"> ● # Must be compatible with proposed Network Switch, Network Video Recorder, and Control System Software. ● Image Sensor: minimum 1/3" Progressive Scan CMOS or higher ● #Resolution: #Minimum of 4MP and Minimum Resolution of 2560 × 1440 ● #Minimum Illumination for Colour: 0.01 Lux or less, B/W: 0 Lux with IR ● Angle Adjustment: Pan: 0° to 360°, tilt: 0° to 90°, rotate: 0° to 360° ● Lens Type: Minimum of 2.8 mm ● Focal Length and Field of View (FOV): Minimum Horizontal FOV 99°, Minimum Vertical FOV 55° and Minimum Diagonal FOV 116° ● Supplemental Illumination, IR up to 30m or more ● Video <ul style="list-style-type: none"> - 50 Hz: At 20 fps (2560 × 1440), At 25 fps (1920 × 1080, 1280 × 720) - 60 Hz:-At 20 fps (2560 × 1440), At 24 fps (1920 × 1080, 1280 × 720) - #Compression: H.265+/H.265/H.264+/H.264 - Bitrate: Minimum range of 32 Kbps to 8 Mbps ● Audio <ul style="list-style-type: none"> - G.711ulaw/G.711alaw/G.722.1/G.726/MP2L2/PCM/AAC-LC - Birate: Minimum of 64 Kbps (G.711 ulaw)/64 Kbps (G.711 alaw)/Minimum of of16 Kbps (G.722.1)/Minimum of 16 Kbps (G.726)/Minimum Range of 32 to 160 Kbps (MP2L2)/Minimum Range of 16 to 64 Kbps (AAC-LC) ● Network <ul style="list-style-type: none"> - Security: Password protection, complicated password, watermark, basic and digest authentication for HTTP, WSSE and digest authentication for Open Network Video Interface, security audit log, host authentication (MAC address) - Protocols TCP/IP, ICMP, DHCP, DNS, HTTP, RTP, RTSP, NTP, IGMP, IPv6, UDP, QoS, FTP, SMTP - User/Host: Up to 32 users, 3 levels: administrator, operator, and user ● #Interface: 1 RJ45 10M/100M self-adaptive Ethernet port ● On-board Storage: Built-in memory card slot, support microSD/microSDHC/microSDXC card, Minimum of 256 GB

TECHNICAL REQUIREMENTS

ANNEX C

S/N.	QTY	DESCRIPTION
4.3	1 Unit	<p>Network INFRARED Camera:</p> <ul style="list-style-type: none"> ● # Must be compatible with proposed Network Switch, Network Video Recorder, and Control System Software. ● Image Sensor: minimum 1/3" Progressive Scan CMOS or higher ● #Resolution: Minimum of 4MP, Minimum Resolution of 2560 × 1440 ● Illumination: Colour: 0.005 Lux or less, B/W: 0 Lux with IR ● Lens: Varifocal, Motor-driven, Range of 2.8mm to 12 mm ● Field of View: Minimum Range of 2.8 to 12 mm: Minimum Range of Horizontal FOV 102° to 31°, Minimum Range of Vertical FOV 55° to 18°, Minimum Range of Diagonal FOV 122° to 36° ● Supplemental Illumination, IR up to 50m or more ● Video <ul style="list-style-type: none"> - 50 Hz: 20 fps (2560 × 1440), 25 fps (1920 × 1080, 1280 × 720) - 60 Hz: 20 fps (2560 × 1440), 30 fps (1920 × 1080, 1280 × 720) - #Compression: H.265+/H.265/H.264+/H.264 - Bitrate Minimum Range of 32 Kbps to 8 Mbps ● Audio <ul style="list-style-type: none"> - G.711ulaw/G.711alaw/G.722.1/G.726/MP2L2/PCM/AAC - Bitrate: Minimum of 64 Kbps (G.711)/16 Kbps (G.722.1)/Minimum of 16 Kbps (G.726)/Minimum Range of 32 to 160 Kbps (MP2L2)/Minimum Range of 16 to 64 Kbps (AAC) ● Network <ul style="list-style-type: none"> - Protocols: TCP/IP, ICMP, HTTP, HTTPS, FTP, DHCP, DNS, DDNS, RTP, RTSP, RTCP, NTP, UPnP, SMTP, IGMP, 802.1X, QoS, IPv6, Bonjour, IPv4, UDP, SSL/TLS - Minimum of 32 users with 3 user levels: administrator, operator, and user ● #Interface: 1 RJ45 10M/100M self-adaptive Ethernet port ● On-Board Storage Built-in memory card slot, support microSD card, up to Minimum of 256 GB
4.4	1 Unit	<p>Network PTZ Camera Controller:</p> <ul style="list-style-type: none"> ● Compatible with proposed Network PTZ Camera ● Interface <ul style="list-style-type: none"> - Minimum of USB Ports 2 × USB 2.0 - Serial Interface Network, RS-232, RS-422, RS-485 - #Interface 10/100/1000 Mbps adaptive ethernet port - WiFi: Supported ● Display: Minimum of 10.1" TFT LCD touchscreen with Minimum Resolution of 1280 × 800 ● Joystick: 4-axis joystick ● Video Output Interface of Minimum Type 1 × HDMI and Minimum 1 × DVI ● Audio Interface <ul style="list-style-type: none"> - Audio Input: 1-ch, 3.5 mm connector - Audio Output: 1-ch, 3.5 mm connector

TECHNICAL REQUIREMENTS

ANNEX C

S/N.	QTY	DESCRIPTION
4.5	1 Unit	<p>Network Video Recorder:</p> <ul style="list-style-type: none"> ● # To be able to trigger recording function/schedule by proposed Control System Software. ● # To equip with minimum 20TB HDD for at least 60 days of recording. ● # Capable of exporting the recorded video file to a portable USB flash drive. ● #IP Video Input of Minimum 16 Channels ● HDMI Output 1-ch, 4K (3840 × 2160)/30 Hz, 2K (2560 × 1440)/60 Hz, 1920 × 1080/60 Hz, 1600 × 1200/60 Hz, 1280 × 1024/60 Hz, 1280 × 720/60 Hz, 1024 × 768/60 Hz ● VGA Output 1-ch, 1920 × 1080/60 Hz, 1280 × 1024/60 Hz, 1280 × 720/60 Hz ● Video Output Mode HDMI/VGA independent output ● Audio Output 1-ch, RCA ● Video Decoding <ul style="list-style-type: none"> - #Format H.265/H.265+/H.264+/H.264 - Recording Minimum Resolution Range of 12 MP/8 MP/6 MP/5 MP/4 MP/3 MP/1080p/UXGA/720p/VGA/4CIF/DCIF/2CIF/CIF/QCIF - Synchronous playback 16-ch - Decoding Capability: 2-ch@12 MP (30 fps)/3-ch@8 MP (30 fps)/6-ch@4 MP (30 fps)/12-ch@1080p (30 fps) ● Audio Compression G.711ulaw/G.711alaw/G.722/G.726/AAC ● Network <ul style="list-style-type: none"> - Minimum of Remote 128 Connections - API ONVIF (profile S/G) SDK, ISAPI - Network Protocol TCP/IP, DHCP, IPv4, IPv6, DNS, DDNS, NTP, RTSP, SADP, SMTP, SNMP, NFS, iSCSI, ISUP, UPnP™, HTTP, HTTPS - #1x RJ-45 10/100/1000 Mbps self-adaptive Ethernet interface ● Auxiliary Interface <ul style="list-style-type: none"> - Minimum of 2 SATA interfaces - Minimum of 10TB capacity for each HDD - Minimum of 2 × USB 2.0

TECHNICAL REQUIREMENTS

ANNEX C

S/N.	QTY	DESCRIPTION
4.6	2 Units	<p>Touchscreen Tablet Controller:</p> <ul style="list-style-type: none"> ● #Processor and Graphics <ul style="list-style-type: none"> - Minimum of Intel N200 with UHD Graphics or Equivalent ● #Memory and Storage <ul style="list-style-type: none"> - Minimum of 8GB LPDDR RAM and Minimum of 128GB UFS Storage ● Display <ul style="list-style-type: none"> - Touchscreen: Minimum of 10.5" Display - Minimum Resolution of 1920 × 1280 - Minimum Aspect ratio of 3:2 - Contrast ratio of Minimum 1500:1 - Colour profile: sRGB and Enhanced or Equivalent - Individually colour-calibrated display or Equivalent - #Touch: Minimum of 10-point multi-touch - Brightness: Minimum of 350 nits ● Ports and Connectivity <ul style="list-style-type: none"> - #USB-C 3.1 (Data, DisplayPort and Charging) - MicroSDXC card reader - 3.5mm headphone jack - Minimum WiFi 6: 802.11ax compatible - Minimum Bluetooth Wireless 5.1 - #Come with USB-C with Network port converters ● Software <ul style="list-style-type: none"> - #Preinstalled Operating System of Windows 11 or equivalent - #Preinstalled Software Control Application for Video Show Relay Switching, Control and Monitoring Functions ● Accessories <ul style="list-style-type: none"> - To include power supply, cables, protective cover, and screen protector. - To include convertors and cables that is needed to connect touchscreen tablet controller to the Video Show Relay System.
4.7	1 Unit	<p>55" Smart TV:</p> <ul style="list-style-type: none"> ● #55" Screen with Minimum Resolution of 4K 3820 x 2160 @ 60Hz ● #Operating System: Google TV or equivalent. ● #Compatible with the proposed Video Show Relay System. ● #Able to output H.265 video source over AVOIP without external convertor ● Minimum of Bluetooth 5.1 ● Minimum Wifi 2.4Ghz/5Ghz ● #Wall Mounting: 200mm x 200mm ● Interface and Ports <ul style="list-style-type: none"> - Minimum of 3x HDMI 2.0 ports - HDMI ARC - Minimum of 2x USB 2.0 port - Minimum of 1x AV In port - #1x RJ-45 10/100/1000 Mbps Ethernet interface ● Accessories <ul style="list-style-type: none"> - To include wall mounting device - To include power supply and necessary cables.

TECHNICAL REQUIREMENTS

ANNEX C

S/N.	QTY	DESCRIPTION
4.8	7 Units	<p>32" Smart TV:</p> <ul style="list-style-type: none"> ● #32" Screen with Minimum Resolution of 1366 x 768 @ 60Hz ● #Operating System: Google TV ● #Compatible with the proposed Video Show Relay System. ● #Able to output H.265 video source over AVOIP without external convertor ● Minimum of Bluetooth 5.1 ● Wifi 2.4Ghz/5Ghz ● #Wall Mounting: 200mm x 200mm ● Interface and Ports <ul style="list-style-type: none"> - Minimum of 2x HDMI 1.4 ports - HDMI ARC - Minimum of 2x USB 2.0 ports - Minimum of 1x AV In port - #1x RJ-45 10/100/1000 Mbps Ethernet interface ● Accessories <ul style="list-style-type: none"> - To include wall mounting device - To include power supply and necessary cables.
4.9	1 Unit	<p>24 Port Network Switch:</p> <ul style="list-style-type: none"> ● # To be compatible with all equipment listed in Video Show Relay System. ● #1 Unit, 1U Rack Mounted ● #24-port 1000BASE-T (RJ45) ● #Minimum of 2-ports x 10GBASE-T (RJ45) all independent ● Minimum of 2-port x 10GBASE-X (SFP+) all independent ● #Minimum of 128 Gbps Non-blocking switching fabric across all ports ● Full L3 Feature set and non-stop forwarding (NSF) stacking ● Mini-USB and RJ45 RS232 console ports and USB storage port ● Management: Out-of-band Web GUI; HTTPs; CLI; Telnet; SSH SNMP, MIBs RSPAN Radius Users, TACACS+ ● #IPv4/IPv6 Multicast filtering: IGMPv3 MLDv2 Snooping, Proxy ASM & SSM IGMPv1,v2 Querier (compatible v3) Control Packet Flooding ● IPv4 / IPv6 Policing and Convergence: Auto-VoIP Auto-iSCSI Policy-based routing (PBR) LLDP-MED IEEE 1588 PTPv2## 1-Step End to-End Transparent Clock ● VLANs: Static, Dynamic, Voice, MAC GVRP/ GMRP Double VLAN mode Private VLANs ● Trunking Port Channel: Distributed LAG across the stack Static or Dynamic LACP (LACP automatically reverts to and from Static LAG) Seven (7) L2/ L3/L4 hashing algorithms ● IPv4/IPv6 Authentication Security: Successive Tiering (DOT1X; MAB; Captive Portal) DHCP Snooping Dynamic ARP Inspection IP Source Guard ● IPv4/IPv6 Static Routing: Port, Subnet, VLAN routing, DHCP Relay; Multicast static routes; Stateful DHCPv6 Server ● IPv4/IPv6 Dynamic Routing: IPv4: RIP, VRRP IPv4/IPv6: OSPF, Proxy ARP, PIM-SM, PIM-DM, 6-to-4 tunnels ● Accessories <ul style="list-style-type: none"> - To include mounting brackets to mount on Show Relay Video Equipment Rack - To include power supply and necessary cables.

TECHNICAL REQUIREMENTS

ANNEX C

S/N.	QTY	DESCRIPTION
4.10	1 Unit	<p>AVOIP Media Processor Workstation:</p> <ul style="list-style-type: none"> ● #Pre-Installed Operating System, Window 11 or equivalent ● #Pre-Installed Control System Software application (Please Refer to Control System Software Requirements) ● #Minimum of Ultra Processor 155H with Arc GPU or Equivalent ● #Minimum of 8Gb DDR5 Ram or more ● Minimum of 1 TB SSD or more ● Connectivity <ul style="list-style-type: none"> - Minimum of 1 HDMI 2.1 - Minimum of 1 USB Type-C ports - #Minimum of 2.5GbE (i226-V) / 10GbE (AQC113) LAN - Minimum of Wi-Fi 6E AX1690i, 802.11ax 2x2 3.0Gbps w/ 6GHz + Bluetooth 5.1 - Minimum of 2 USB 3.2 Gen2 Type-A connectors ● Accessories <ul style="list-style-type: none"> - To include mounting brackets, tray, and/or holder to mount unit on to Show Relay Video Equipment Rack. - To include power supply and necessary cables.
4.11	4 Units	<p>IP Media Decoder:</p> <ul style="list-style-type: none"> ● # To be compatible with Venues Dual Display Monitor and proposed HDMI to SDI converter. ● Video Output Resolution Minimum Range: 480i, 480p, 576i, 576p, 720p, 1080i, 1080p60, 2160p60 10-bit (4Kp60) HDR10+ and HLG ● #Video Codecs: AV1, HEVC/H.265, AVC/H.264 (MPEG-4, Part 10), MPEG-2, VP9 ● Audio Codecs: Dolby Digital, Dolby Digital Plus, LC-ACC & HE-AAC ● IP Streaming Format: RTSP, HLS, LL-HLS, Dash, LL- Dash, SRT, HTML5 Video-Tag ● Networking: IGMPv2 / IGMPv3 UDP-Multicast, UDP-Unicast ● Connectivity: <ul style="list-style-type: none"> - #Minimum of 1 HDMI 2.1 - Minimum of 2 USB 2.0 - Minimum of 1 RS232 - #1x RJ-45 10/100/1000 Mbps Ethernet interface ● Accessories <ul style="list-style-type: none"> - To include power supply and necessary cables.
4.12	4 Unit	<p>HDMI to SDI Converter:</p> <ul style="list-style-type: none"> ● # To be compatible with Venues Dual Display Monitor and proposed IP Media Decoder. ● #Minimum of 1 SDI and 1 HDMI 2.0 Video Output ● #Minimum of 1 SDI and 1 HDMI 2.0 Video Input ● Auto detection of SD, HD or 6G-SDI ● HDMI Video Standards: 625i50 PAL, 525i29.97 NTSC, 720p50, 720p59.94, 720p60, 1080p23.98, 1080p24, 1080p25, 1080p29.97, 1080p30, 1080p50, 1080p59.94, 1080p60, 1080i50, 1080i59.94, 1080i60, 2160p23.98, 2160p24, 2160p25, 2160p29.97, 2160p30 ● SDI Compliance: SMPTE 259M, SMPTE 292M, SMPTE 296M, SMPTE 372M, SMPTE 424M, SMPTE 425M, SMPTE ST-2081, ITU-R BT.656 and ITU-R BT.601 ● HD Video Standards: 720p50, 720p59.94, 720p60, 1080p23.98, 1080p24, 1080p25, 1080p29.97, 1080p30, 1080p50, 1080p59.94, 1080p60, 1080i50, 1080i59.94, 1080i60 ● Accessories <ul style="list-style-type: none"> - To include power supply and necessary cables.

TECHNICAL REQUIREMENTS

ANNEX C

S/N.	QTY	DESCRIPTION
4.13	1 Unit	<p>Stage Manager Control Desk:</p> <ul style="list-style-type: none"> ● #Material: Sheet Metal Steel ● #Caster Wheel with lock ● To include a put-out drawer ● To include a pair of mounted power point ● To include 2 x XLR Male point and 2 x XLR Female point ● Cable access hole at bottom of the Control Desk ● To include 7U or more rack space ● Must be able to accommodate to our current equipment (Paging system, Audio Relay Control and Dual Display monitor) and vendor proposed equipment ● Dimension: refer to Appendix iii - Technical specification for Stage Manager Control Desk ● Design is not drawn to scale, Vendor is required to take measurements, and able to propose, customize and build according to safety guidelines and user ergonomics ● Please refer to Appendix iii - Technical specification for Stage Manager Control Desk for details.

5. Equipment Count (Cameras, TV Monitors and Accessories) – For Tenderer’s Reference

5.1. Concert Hall

Description	Quantity
PTZ Cameras	3
Venue CCTV Cam	5
FOH CCTV Cam	2
IR Camera	1
Venue Monitor Display 32"	2
Followspot Room Monitor Display 32"	1
Control Room Monitor Display 32"	3
Dressing Room Monitor Display 32"	7
FOH Monitor Display 55"	2
Holding Room Monitor Display 55"	1
Dual Display Monitor Outputs with converters	4
VESA TV Mount with Swivel & Articulating Arm	2
VESA TV Mount with "C" Clamp for mounting on pipe (for control room & follow spot)	4
VESA TV Wall Mount, TILT Only (for Holding Rm, Dressing Rms & FOH)	10

5.2. Drama Theatre

Description	Quantity
PTZ Cameras	2
Venue CCTV Cam	3
FOH CCTV Cam	3
IR Camera	1
Venue Monitor Display 32"	6
Followspot Room Monitor Display 32"	1
Control Room Monitor Display 32"	3
Dressing Room Monitor Display 32"	4
FOH Monitor Display 55"	3
Holding Room Monitor Display 55"	0
Dual Display Monitor Outputs with converters	4
VESA TV Mount with Swivel & Articulating Arm	6
VESA TV Mount with "C" Clamp for mounting on pipe (for control room & follow spot)	4
VESA TV Wall Mount, TILT Only (for Holding Rm, Dressing Rms & FOH)	7

TECHNICAL REQUIREMENTS**ANNEX C****5.3. Studio Theatre**

Description	Quantity
PTZ Cameras	1
Venue CCTV Cam	3
FOH CCTV Cam	1
IR Camera	1
Venue Monitor Display 32"	2
Followspot Room Monitor Display 32"	0
Control Room Monitor Display 32"	3
Dressing Room Monitor Display 32"	2
FOH Monitor Display 55"	1
Holding Room Monitor Display 55"	0
Dual Display Monitor Outputs with converters	4
VESA TV Mount with Swivel & Articulating Arm	2
VESA TV Mount with "C" Clamp for mounting on pipe (for control room & follow spot)	3
VESA TV Wall Mount, TILT Only (for Holding Rm, Dressing Rms & FOH)	3

6. Control System Software Requirements

Installation and programming of the Control System Software in each respective venue (Concert Hall, Drama Theatre, Studio Theatre) to include, but not limited to the following requirements:

- 6.1. # The control system software must have the ability to route any of the camera's sources to any of the TV Monitor destinations.
- 6.2. # All video signals to be in the IP network.
- 6.3. The control system software web user interface (UI) must be able to name all the sources and destinations using numbers, alphabet, and location name in the user interface for ease of identification.
- 6.4. # The control system software web user interface must be intuitive to easily assign any of the sources to any of the TV monitors via a XY panel layout.
- 6.5. The control system software must be able to identify all the sources and destinations and show the connectivity status within the user interface.
- 6.6. The control system software must have the capability to control the camera sources for pan, tilt, zoom in and zoom out functionality via a wired network using RS45, RS422 and/or IP.
- 6.7. # The control system software must have the capability to remote control via a touchscreen tablet.
- 6.8. # Switching of the sources must not exceed 150 milliseconds of delay and it must be seamless without any glitch on the destination TV monitors.
- 6.9. The control system software user interface must have the capability for different user level access and functionality. It must support up to no less than 3 types of user access.
- 6.10. # The proposed AVOIP Media Processor Workstation must be able to run the proposed Control System Software.
- 6.11. The proposed AVOIP Media Processor Workstation running the Control System Software must not exceed 70% threshold for both CPU and RAM usage.
- 6.12. # The software must have the ability to customise the video recording schedule, trigger the scheduled recording, save the recording and be able to automatically rename the video file to the recorded venue, date, and time.
- 6.13. The software must have the ability to add in addition camera source and/or output video source to addition display monitor.
- 6.14. The software must be capable of logging systems activities, the logging shall capture all user activities, routing activities, server processes and database activities.
- 6.15. # An executable file of the Control System Software to be handled over to us for backup and restore of software purposes.

Annex D : SCOPE OF WORKS

TO SUPPLY, DELIVER, INSTALL, CONFIGURE, SYNCHRONISE, PROGRAMME, TEST AND COMMISSIONING OF VIDEO SHOW RELAY SYSTEMS WITH VIDEO RECORDING CAPABILITY IN CONCERT HALL, DRAMA THEATRE AND STUDIO THEATRE AT SCHOOL OF THE ARTS, SINGAPORE

A. SCOPE OF WORKS

- 1) To propose, supply, deliver and install all components to meet the Annex C - Technical Requirements, Appendix i - Video Show Relay System Equipment Layout Plan, Appendix ii - Video Show Relay System Signal Block Diagram and Appendix iii - Technical specification for Stage Manager Control Desk to the specifics of the Performing Arts Venues in SOTA. Please refer to Annex C and Appendix i, ii and iii attached.
- 2) To provide a trained professional engineer/ certified professional installer / licensed electrical worker for the proposed Video Show Relay system, including all electrical and network cabling, system, network configuration and control software system installation, which include all system materials, component parts and its control touch screen of the actual installation of the proposed system. Please attach copies of certification/ license/ letter of authorisation or equivalent documentation where applicable.
- 3) # The Contractor shall assign one project manager to be responsible for the coordination and supervision of the day-to-day operation, and act as liaison with the Company, throughout the entire project.
- 4) Job provision of all preliminaries, materials, labours, transportation, tools, machinery, all other equipment and accessories, taxes, authority fees, licences, Professional Engineer (PE) endorsement if required in the Works, and all other miscellaneous fees for the efficient execution of the Works in accordance with the relevant requirements to the entire satisfaction of the Company.
- 5) The Contractor to provide daily site supervision throughout all works periods in the venues with surface protection, cleaning and reinstatement including touch up and end-finishing works where applicable, (i.e. motor or mechanical installation, carpentry works, painting of electrical cable or parts component trunking to be the same colour as wall surfaces)
- 6) To supply and install all labour, materials necessary, component parts, electrical parts, mounting brackets, connectors, and cables, required for the video show relay installation, including termination, dismantling and disposal of the current equipment/ system before installation. Existing cables that are not in use to be bundled/secured and labelled. Cables patched in venues patch bay that are not in used, are to be removed.
- 7) Network cable used for installation to be Cat6 cable or of higher specification.
- 8) Fibre optic cable, if used for installation to be LC, duplex and OM3 multimode or higher specification.
- 9) All non-fibre optic cables installed for the proposed system must be fully concealed using conduits, trunking and firmly secured. Cable installations within fire escape routes, as required by fire safety regulations, to be fully housed in metal conduit and/or metal trucking. Colour-matching of the cable trunking to follow the location's background colour.
- 10) Joining of cables is strictly prohibited. Cables for video must be continuous from point to point, equipment to equipment.
- 11) Should additional power outlets for equipment be required, the Contractor has to draw the power from a general power outlet nearest to the installation location.
- 12) Any device (converters, cable connectors) and/or spare extended cables to installed 60cm above ground to include a box with vent outlet to contain the device/cable to prevent from tampering.

- 13) To label each equipment installed. To label all incoming and outgoing cables.
- 14) Functional tests to be conducted at different stages of the installation to ensure all installed components and systems of the video show relay at each venue to be in full functioning condition.
- 15) # The complete functional system tests must satisfy all the scenario settings requirements specified under the compulsory operation requirements for the video show relay in the requirement specifications in Annex C - Technical Requirements. Testing and commissioning of all system functions, including checking of all video feeds, signal flow and its functions, to ensure that the video show relay systems installed are operating well in a manner consistent with the requirements.
- 16) # To conduct a User Acceptance Test (UAT) for complete functionality on the control system of the video show relay system in each venue.
- 17) All damages caused during the installation shall be made good by the Contractor to match the existing and surrounding finishes to the Company's satisfaction and within the stipulated time frame as agreed with the Company. All costs in connection with such works shall be deemed to be included in the total Contract Sum. Failing which, any opportunity loss, costs and expenses incurred by SAS in assuming remedy to such damages shall be charged fully to the Contractor.
- 18) To provide an Operations and Maintenance Manual upon completion of installation in each venue. To include venue-specific, detailed schematic drawings with complete part and model number, and labelling of installed cables for all the three venues (Concert Hall, Drama Theatre and Studio Theatre).
- 19) Configurations for the Video Show Relay functions to be submitted for the entire project upon completion of installation in all three venues (Concert Hall, Drama Theatre and Studio Theatre), showing each individual functions, and settings in relation to the system.
- 20) An executable file of the Control System Software for the Video Show Relay control system to be submitted upon completion of the installation in all three venues (Concert Hall, Drama Theatre and Studio Theatre), for software backup and restoration in the event of error.
- 21) The Contractor shall provide a comprehensive training covering the usage, and user configuration training on the proper operations and maintenance of the video show relay systems. The training package should include minimum two (2) group-trainings; the Contractor to propose numbers of hours per training. The training shall be video recorded by the Company for archival use.
- 22) a) To provide at least twenty-four (24) months of warranty period for the equipment from the date of commissioning of all Works
b) To provide at least twelve (12) months of warranty period and defect liability coverage for the installation, configuration, and workmanship of the project from the date of commissioning of all Works.

- 23) To provide at least twenty-four (24) months of two (2) times yearly maintenance service as part of the contract for the installed video show relay system, from the date of commissioning of all Works fully completed in all three venues, which include but not limited to:
- Preventive maintenance for the video show relay system installed, to include all installed parts, system materials replacement when required, including the control system software installed.
 - Checking, replacement and re-termination, if necessary, for all electrical and network cables, components, and connectors.
 - Provide help desk services to troubleshoot any minor functional issues encountered during production setups.
 - Provide on-site call-back service during office hours to attend and troubleshoot fault and repair of breakdown:
 - a) Normal Call Service: The Contractor’s Service Technician required to be On-site within twenty-four (24) hours
 - b) Urgent Call Service: The Contractor’s Service Technician required to be On-site within four (4) hours
 - The maintenance and call-back services shall include all transportation and labour to perform the maintenance and breakdown services required under the specifications at no cost.

- 24) Service period from installation to completion in the venue must be completed within the stipulated period of each venue as follows:

Drama Theatre	No longer than three (3) weeks
Concert Hall	No longer than three (3) weeks
Studio Theatre	No longer than two (2) weeks

- 25) All Works to be carried out during Hours of Work (0830hrs - 2130hrs) on Monday to Saturday excluding Public Holidays and based on the set of dates provided by the Company. Venue availability to be notified by SAS authorised personnel at least four (4) weeks in advance before the installation period.
- 26) Should overtime work be necessary for the Contractor to complete the Works by the date and time agreed, no additional charges will be paid to the Contractor for such overtime. Any overtime and related costs and revenue loss incurred by the Company will be fully borne by the Contractor.
- 27) Should the Contractor deem it necessary to work beyond the Hours of Work (from 0830hrs to 1800hrs) to complete the Contract within the given time, the quoted prices in Schedule of Price should be inclusive of such overtime.
- 28) The above general description of the Scope of Works is only for the guidance of the Contractor and any error or omission shall not constitute a ground for claims by the Contractor. The Contractor shall investigate the actual extent and nature of the Works comprised in this Contract prior to submission of his quotation. Any doubts should be clarified with the Company before the submission as no claims arising out of lack of clarity or availability of information will be entertained.

B. LIQUIDATED DAMAGES

1. Any failure by the Contractor or any of its employees in meeting the requirements and service level agreements shall result in liquidated damages and penalties. Please refer to Table 1 below. All deductible sum(s) shall be deducted from the Contractor’s invoice accordingly.

Table 1: Liquidated Damages

S/N	Description	Concert Hall	Drama Theatre	Studio Theatre
1.	Failure to complete maintenance session per venue within the stipulated time frame	S\$6,300/day	S\$3,400/day	S\$2,000/day
2.	Failure to meet the Emergency Response for Corrective Maintenance call back service	S\$4,600/case	S\$3,000/case	S\$1,500/case

The total accumulated Liquidated Damages shall be capped at 15% of the base contract sum.

2. The Contractor shall take all necessary precautions to prevent damage to any of the Company’s property, fixtures or fittings within the venues and the school’s vicinity. Any disturbance or damages to the existing part of the building during the maintenance service tasks must be rectified and made good by the Contractor at no additional costs to the Company. Any opportunity loss, costs and expenses incurred by the Company during the rectification period for such damages, shall be fully charged to the Contractor.
3. All damages caused during the project shall be made good by the Contractor to match the existing and surrounding finishes to the Company’s satisfaction and within the stipulated timeframe as agreed with the Company. All costs in connection with such works shall be deemed to be included in the total Contract Sum. Failing which, any opportunity loss, costs and expenses incurred by SAS in assuming remedy to such damages shall be charged fully to the Contractor.

C. CONDITION OF WORK

1. This quotation shall include the provision of all transportation, labour, tools, machinery and all other equipment, license, and accessories necessary for the efficient execution of the works in accordance with the relevant requirements to the entire satisfaction of SOTA. Any spare parts replacement will be based on pre-submitted SOR/quotation before works.
2. Insurance – The Contractor is solely responsible for ensuring adequate insurance coverage for All Risks, Public Liability, Workmen’s Compensation, and such other risks as the Employer may determine and notify to the Contractor. Public liability cover shall be a minimum of \$1,000,000 for any one occurrence.
3. Indemnity – The Contractor shall indemnify the SOTA for all claims, proceedings, actions, damages, costs, expenses, and liabilities arising from or in connection with the carrying out of Works.
4. The Contractor shall be responsible for all acts, omission and/or conduct of its workers and where permitted, it’s sub-contractors and their workers.
5. The Contractor shall observe and comply with all rules and regulations prescribed by SOTA. Should the Contractor fail to observe any of the rules and regulations, SOTA reserves the right to remove the Work in part or in total. The Contractor shall reimburse SOTA for all costs incurred in removal of and fully indemnify SOTA against any claim, damages, costs and/or expenses arising out of the Works or any part thereof.
6. If any part of the Building is damaged during the provision of the Works or caused by any act or omission of the Contractor, its employees, sub-contractors and/or sub- contractor’s employees, SOTA reserves the sole right and discretion to determine the costs of repair and deduct such costs from the monies due to the Contractor to pay for the repair.

Annex E :
STATEMENT OF COMPLIANCE

STATEMENT OF COMPLIANCE

*The indication of Compliance (C) or Non-compliance (NC) will be deemed to be applicable to each **main** section, unless it is clearly stated to be otherwise.

** Please indicate the specific items/points of non-compliance where applicable and proposed equivalent customisation or/and workable solutions.

Specification	Compliance (C/NC)*	Explanatory Remark**
ANNEX A - CONDITIONS OF CONTRACT		
1		
1.1		
1.2		
1.3		
1.4		
1.5		
2		
2.1		
2.2		
2.3		
2.4		
3		
3.1		
3.2		
3.3		
3.4		
3.5		
3.6		
4		
4.1		
4.2		
4.3		
4.4		
5		
5.1		
5.2		
5.3		
5.4		
5.5		
5.6		
5.7		
5.8		
5.9		
6		
6.1		
6.2		
7		
8		
9		
10		
10.1		
10.2		
11		
12		
12.1		
12.2		
12.3		
13		
14		
15		
15.1		
15.2		
15.3		

Specification	Compliance (C/NC)*	Explanatory Remark**
15.4		
16		
17		
18		
19		
20		
20.1		
20.2		
20.3		
20.4		
21		
22		
22.1		
22.2		
22.3		
22.4		
23		
24		
25		
26		
26.1		
26.2		
ANNEX C – TECHNICAL REQUIREMENTS		
1.1		
1.2		
1.3		
1.4		
1.5		
1.6		
1.7		
1.8		
1.9		
1.10		
2.1		
2.2		
2.3		
2.4		
2.5		
2.6		
2.7		
2.8		
2.9		
2.10		
2.11		
2.12		
2.13		
2.14		
3.1		
3.2		
3.3		
3.4		
3.5		
3.6		
3.7		
3.8		
3.9		
3.10		
3.11		
3.12		
3.13		
3.14		
4.1		

Specification	Compliance (C/NC)*	Explanatory Remark**
4.2		
4.3		
4.4		
4.5		
4.6		
4.7		
4.8		
4.9		
4.10		
4.11		
4.12		
4.13		
5.1		
5.2		
5.3		
6		
6.1		
6.2		
6.3		
6.4		
6.5		
6.6		
6.7		
6.8		
6.9		
6.10		
6.11		
6.12		
6.13		
6.14		
6.15		
ANNEX D – SCOPE OF WORKS		
A		
A1		
A2		
A3		
A4		
A5		
A6		
A7		
A8		
A9		
A10		
A11		
A12		
A13		
A14		
A15		
A16		
A17		
A18		
A19		
A20		
A21		
A22		
A23		
A24		
A25		
A26		
A27		
A28		
B		

Specification	Compliance (C/NC)*	Explanatory Remark**
B1		
B2		
B3		
C1		
C2		
C3		
C4		
C5		
C6		

We fully understand and agree that notwithstanding the fact that the Statement of Compliance as herein declared is subjected to the Company's acceptance.

Dated this _____ day of _____ 202_.

NAME AND SIGNATURE :
(AUTHORISED REPRESENTATIVE) _____

NAME :
(WITNESS) _____

DESIGNATION :
(AUTHORISED REPRESENTATIVE) _____

DESIGNATION :
(WITNESS) _____

DATE : _____

DATE : _____

COMPANY STAMP :
(AUTHORISED REPRESENTATIVE) _____

COMPANY STAMP :
(WITNESS) _____

COMPANY NAME :
(AUTHORISED REPRESENTATIVE) _____

COMPANY NAME :
(WITNESS) _____

Annex F :
CONSORTIUM DECLARATION

CONSORTIUM DECLARATION¹

THIS DECLARATION is made on the ____ day of _____ 20____ where the undersigned:

(Name of consortium, address, representative), in our capacity of Tenderer for the Replacement of Video Show Relay Systems with Maintenance Services for School of the Arts, Singapore. (Tender Reference: SAS/OP/2024/013/T)

1. *(Name of company, address, representative, court registration data)*, in our capacity of **leading organisation** of *(Name of consortium)*, Tenderer for the Replacement of Video Show Relay Systems with Maintenance Services for School of the Arts, Singapore.
2. *(Name of company, address, representative, court registration data)*, in our capacity of **member** of *(Name of consortium)*, Tenderer for the Replacement of Video Show Relay Systems with Maintenance Services for School of the Arts, Singapore.
3. *(Name of company, address, representative, court registration data)*, in our capacity of **member** of *(Name of consortium)*, Tenderer for the Replacement of Video Show Relay Systems with Maintenance Services for School of the Arts, Singapore.
4. *(Insert all members of the Consortium).*
5. *(Insert all members of the Consortium).*

HEREBY SOLEMNLY DECLARE that at the time of Tender Submission:

6. We have reached a partnership contract, we understand our role and responsibilities with regard to the above project and we agree to comply with the established good partnership practices if we are shortlisted.
7. We declare that if we are approved and subsequently invited to submit offers, our proposed services and work methodology will be strictly followed.
8. We agree that our offer be disqualified in case of gross incompliance.
9. We undertake that in case we are eventually selected as a Contractor for the Replacement of Video Show Relay Systems with Maintenance Services for School of the Arts, Singapore, to sign a detailed contract with precise distribution of responsibilities, thereby making this Contract an integral part of our Consortium contract and submit it to the Company.
10. We will be jointly and severally responsible for performance of the contract if the contract is awarded to the Consortium.
11. We will not participate in this Invitation to Tender procedure with a separate proposal on our own, including as a member of another Consortium.

¹ To be jointly completed by the applicant and by all members of the Consortium.

FOR THE CONSORTIUM	
Authorised Signature:	Declared on (Date):
Company Name and Stamp:	Name and Designation:
FOR THE LEADING ORGANISATION	
* Type of Services to be provided:	
Authorised Signature:	Declared on (Date):
Company Name and Stamp:	Name and Designation:
FOR THE MEMBERS(1)	
* Type of Services to be provided:	
Authorised Signature:	Declared on (Date):
Company Name and Stamp:	Name and Designation:
FOR THE MEMBERS(2)	
*Type of Services to be provided:	
Authorised Signature:	Declared on (Date):
Company Name and Stamp:	Name and Designation:
FOR THE MEMBERS(3)	
* Type of Services to be provided:	
Authorised Signature:	Declared on (Date):
Company Name and Stamp:	Name and Designation:
FOR THE MEMBERS(4)	
* Type of Services to be provided:	
Authorised Signature:	Declared on (Date):
Company Name and Stamp:	Name and Designation:

(Insert all members of the Consortium)

*** To indicate the Type of Services to be provided by each member for this Project.**

All members are required to submit ACRA and Project Reference (refer to Schedule 1, IT/1 to IT/11)

Appendix i :
VIDEO SHOW RELAY SYSTEM
EQUIPMENT LAYOUT PLAN

Legends:

 - Dual Screen Monitor

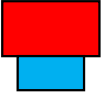
 - TV Monitor

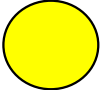
 - PTZ Camera

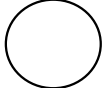
 - Infra-Red Camera

 - CCTV Camera

 - Show Relay Video Equipment Rack
(At Patch Bay)

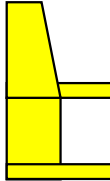
 - SM Desk

Concert Hall

Concert Hall Catwalk Bridges

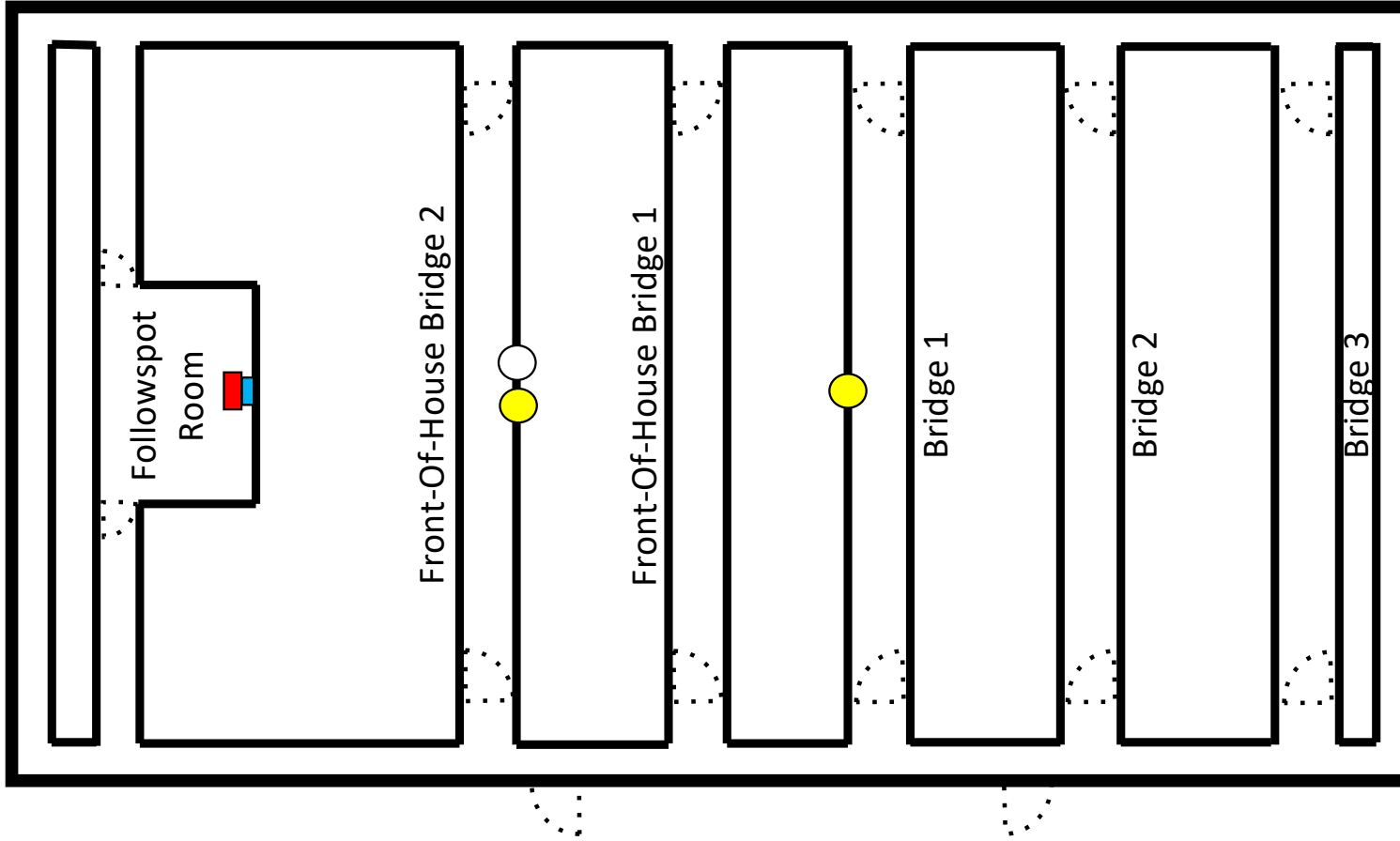

Concert Hall Main Auditorium and Stage



Concert Hall Dressing Rooms Level 1

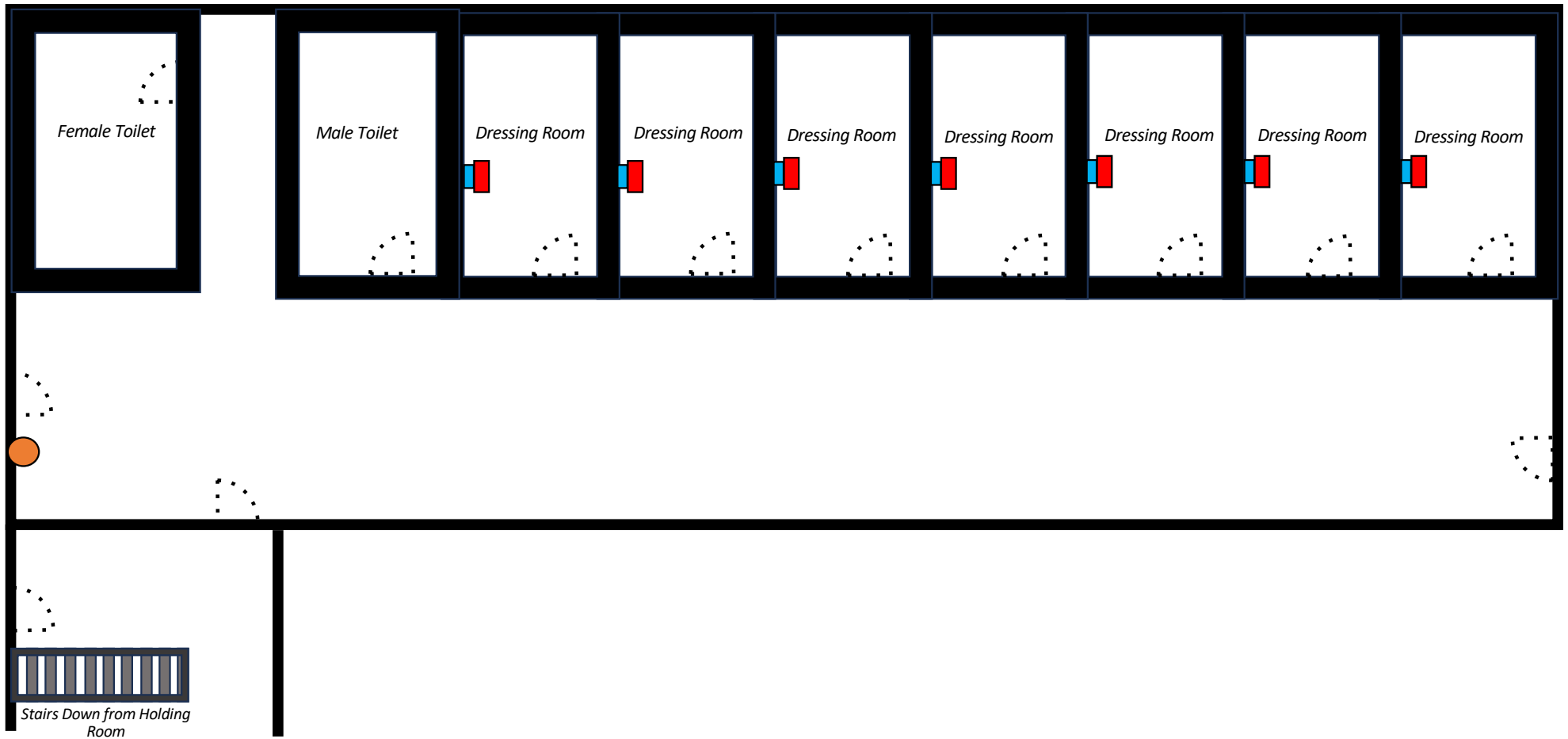

Drama Theatre

Drama Theatre Fly and Catwalk Level

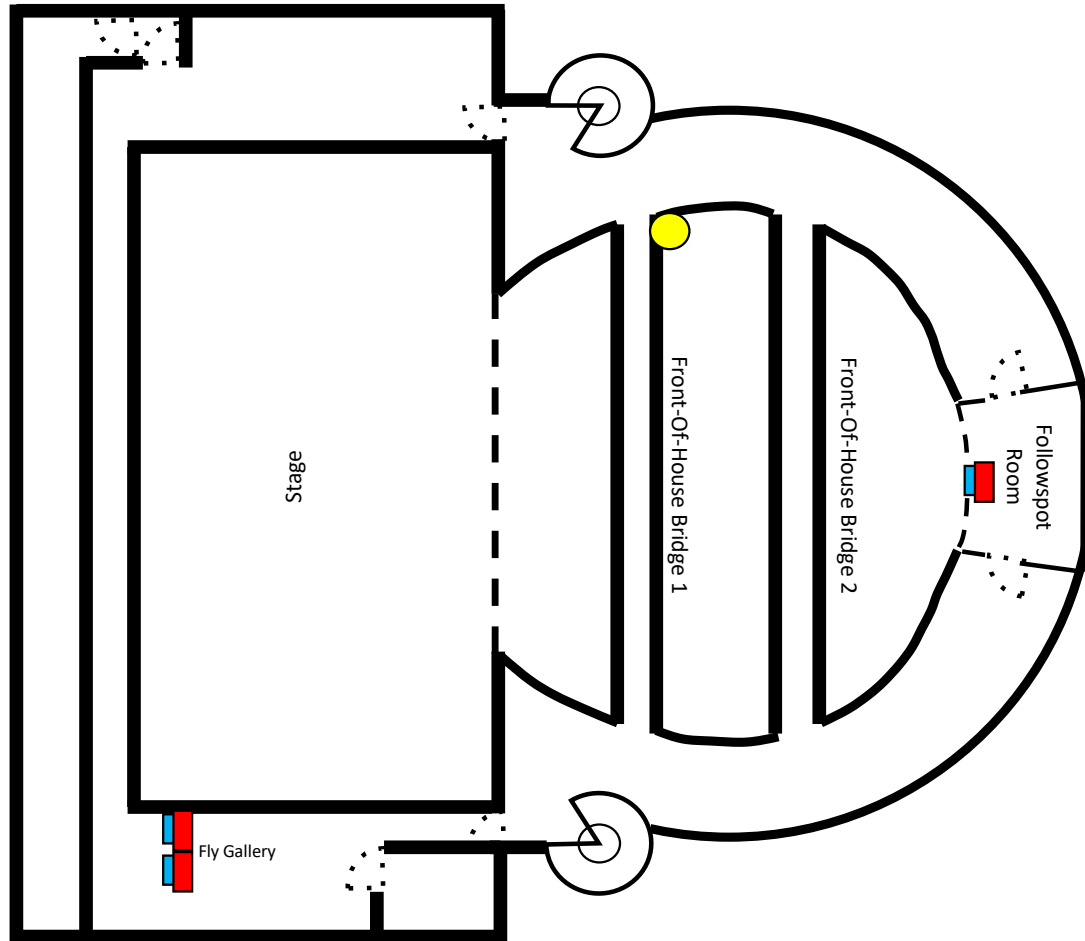

Drama Theatre
Circle Level

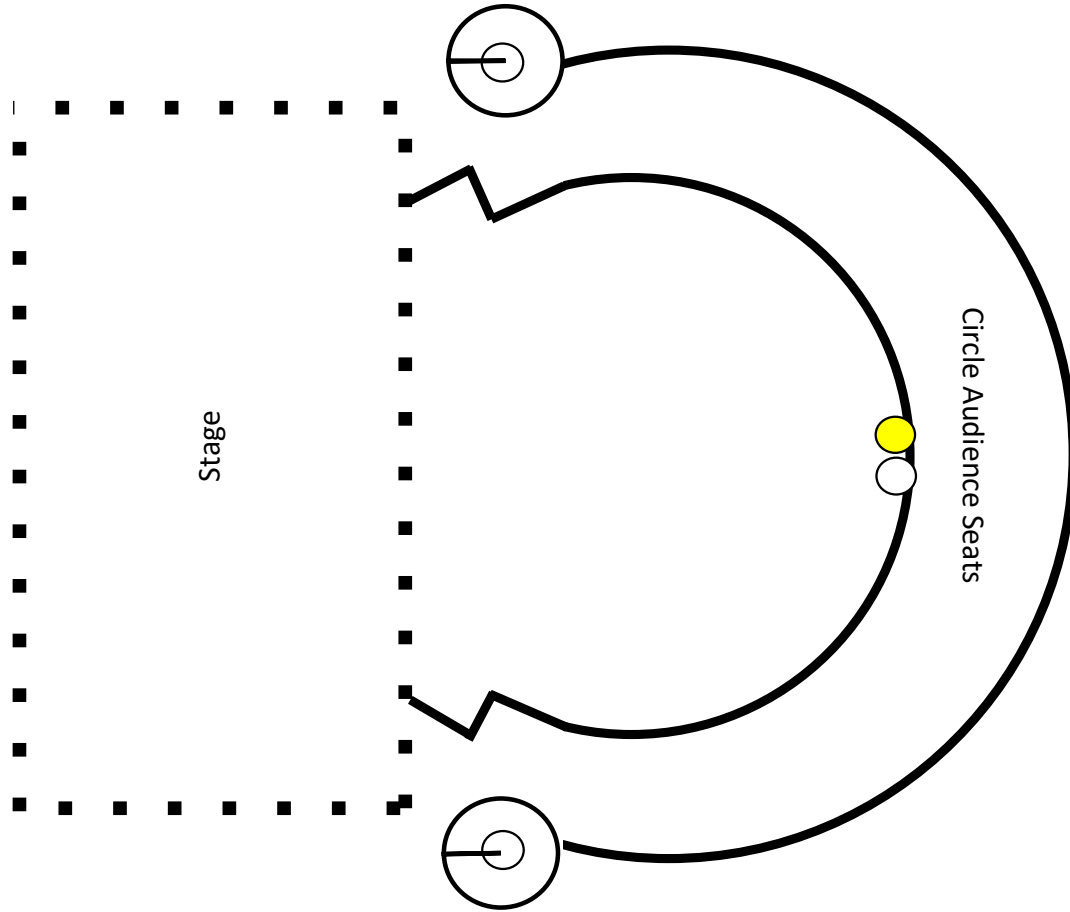

Drama Theatre Stage and Dressing Rooms Stall Level

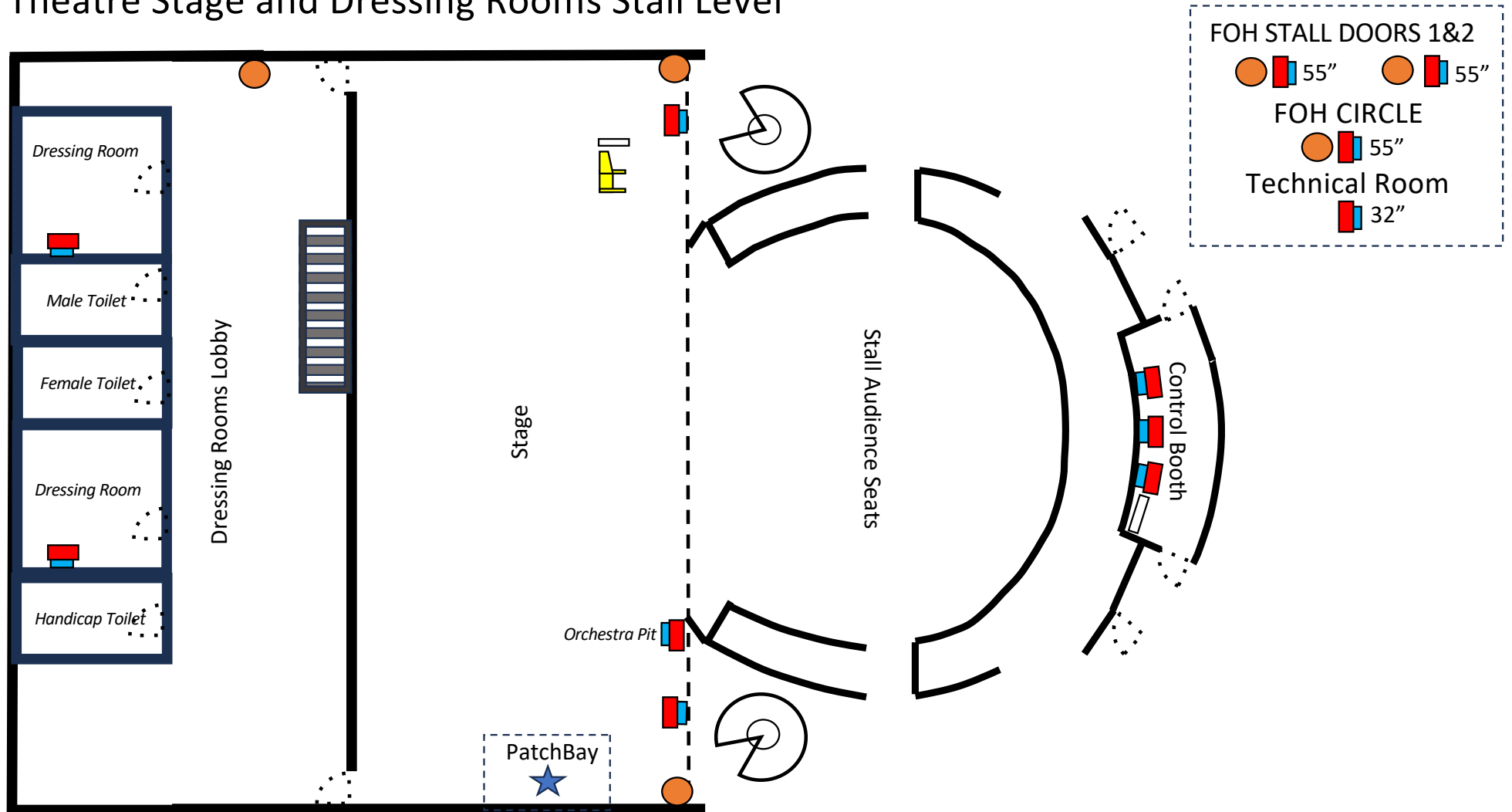

Drama Theatre Dressing Rooms Level 2

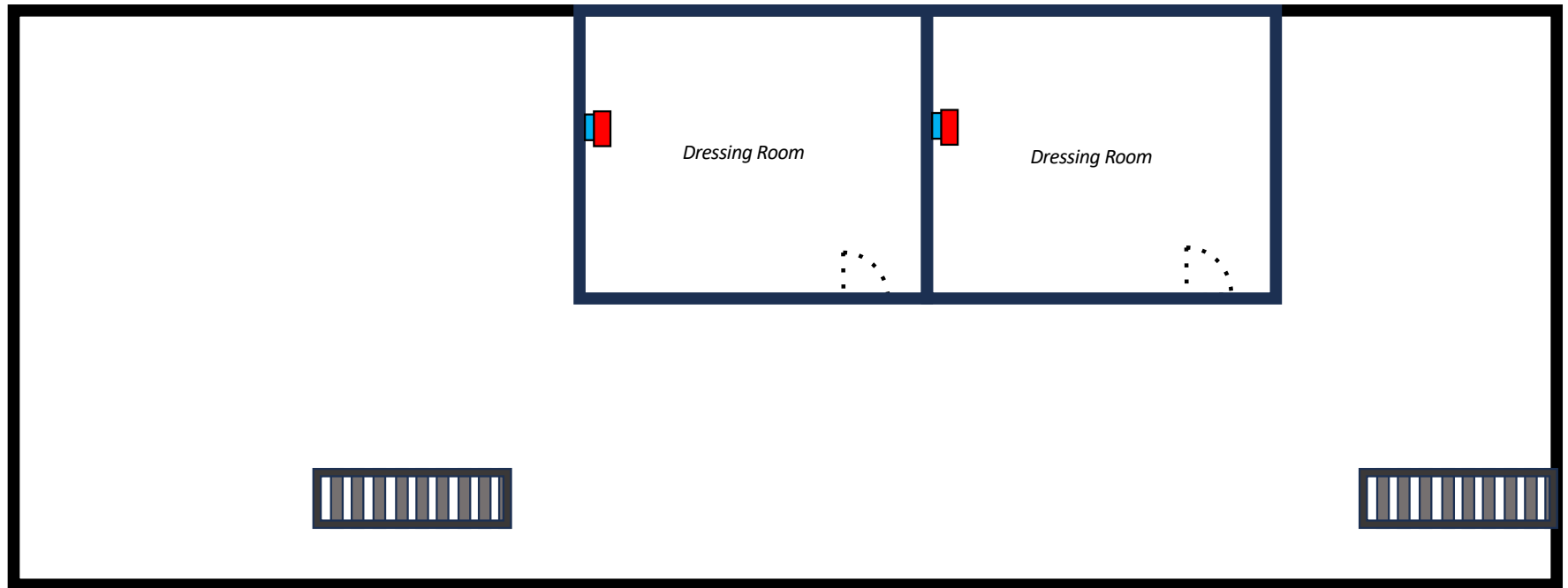

Studio Theatre

Studio Theatre Mezzanine

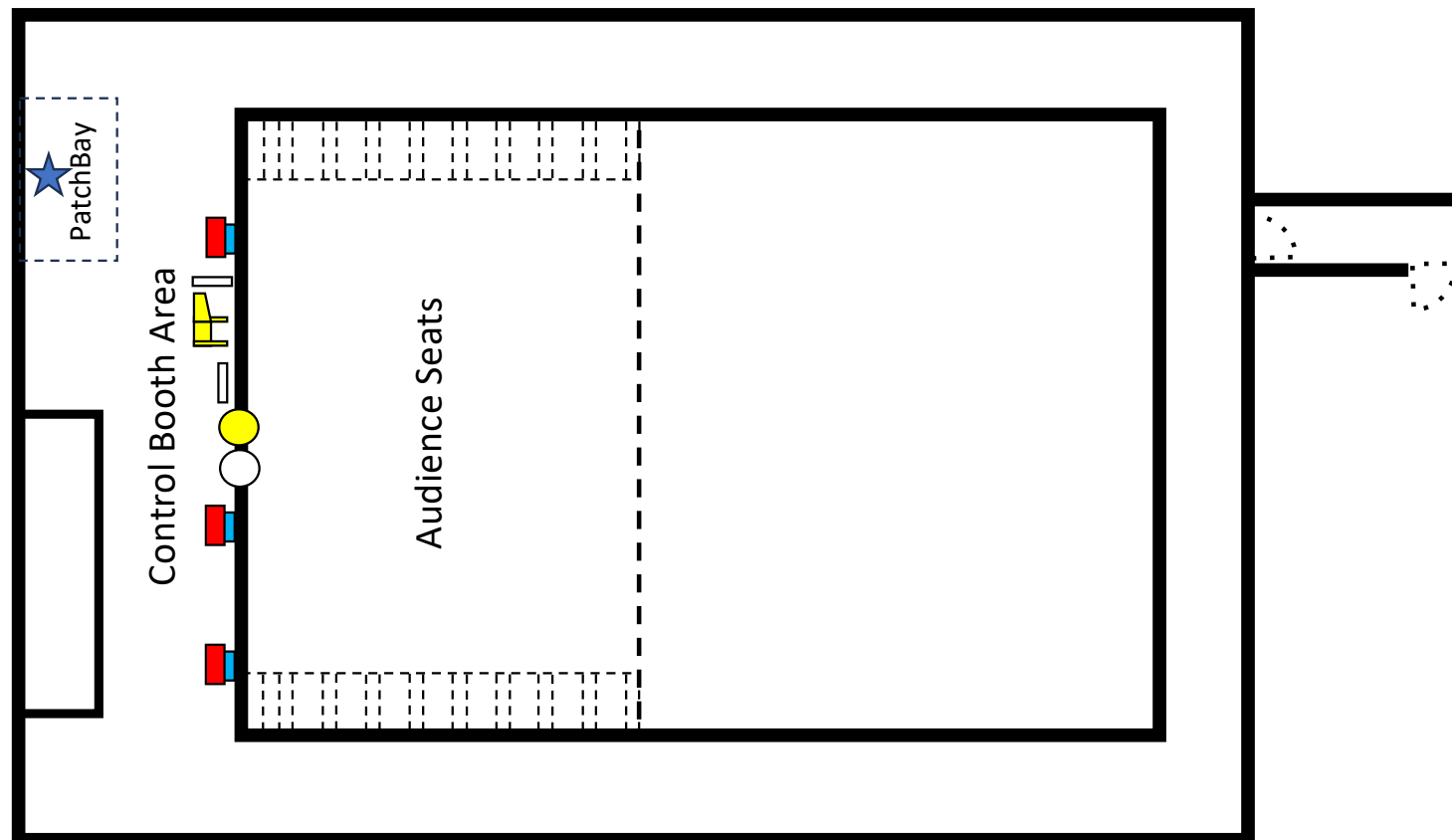

Studio Theatre
Stage Level

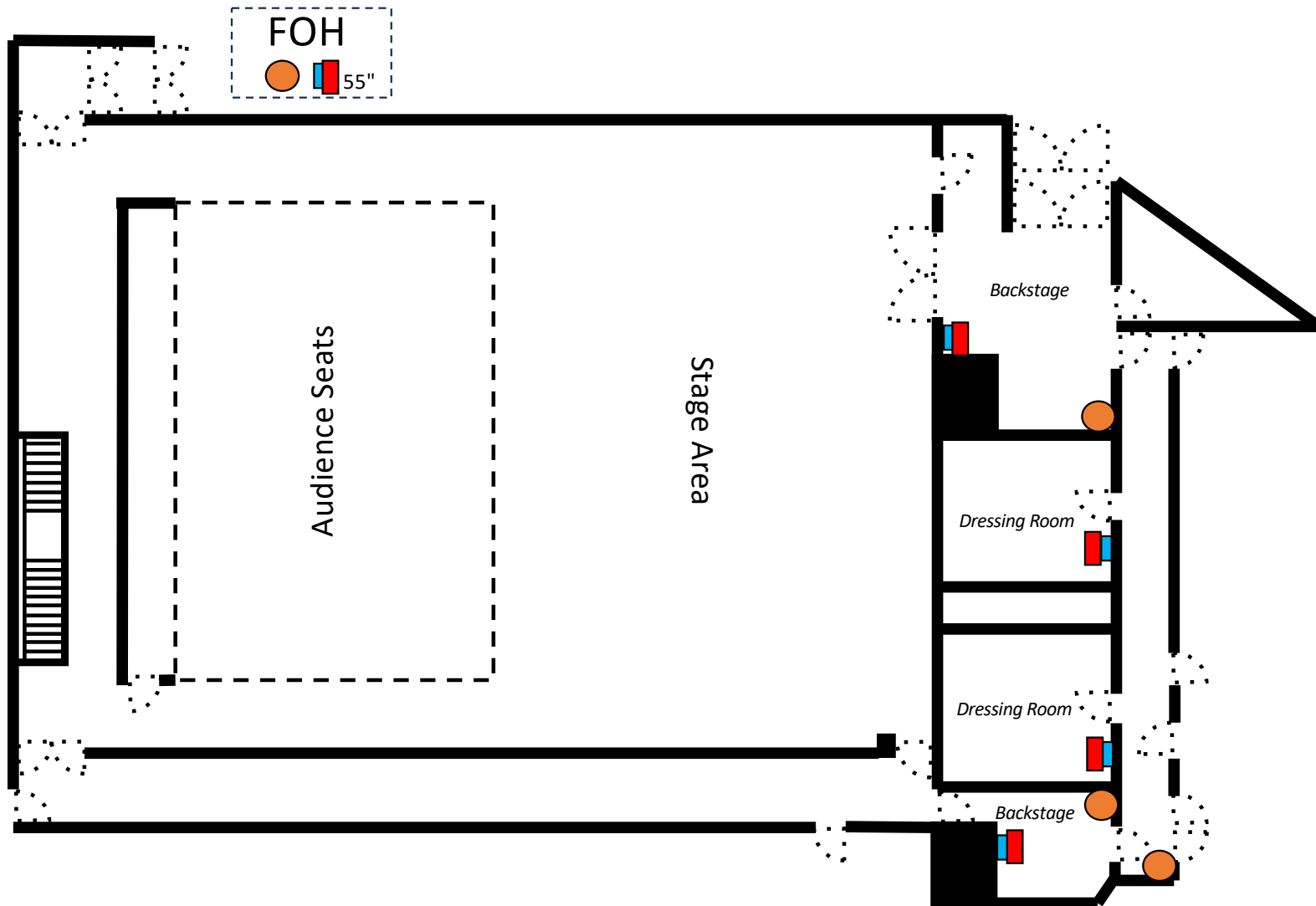

Appendix ii :
VIDEO SHOW RELAY SYSTEM
SIGNAL BLOCK DIAGRAM

CONCERT HALL

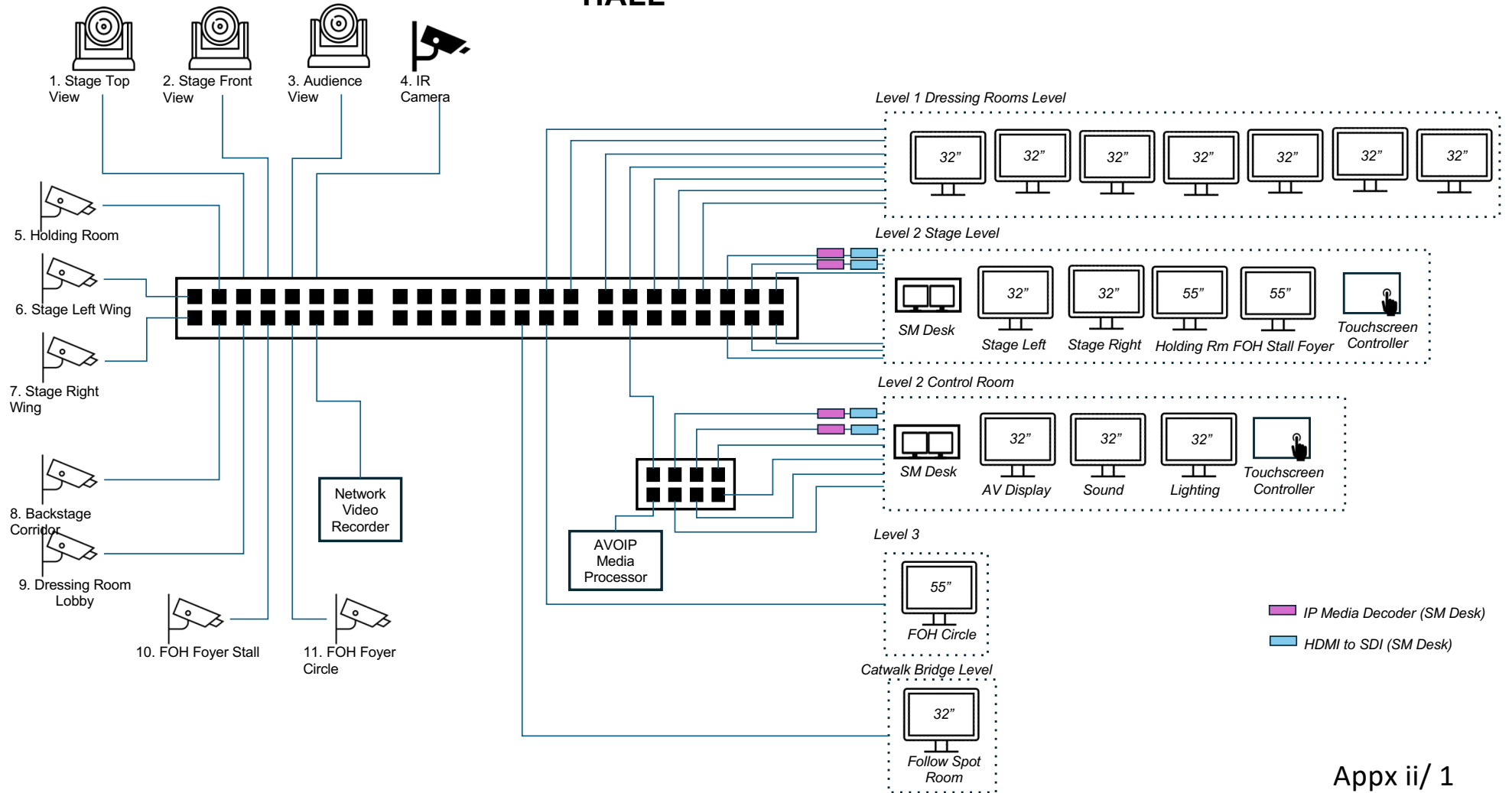

DRAMA THEATRE

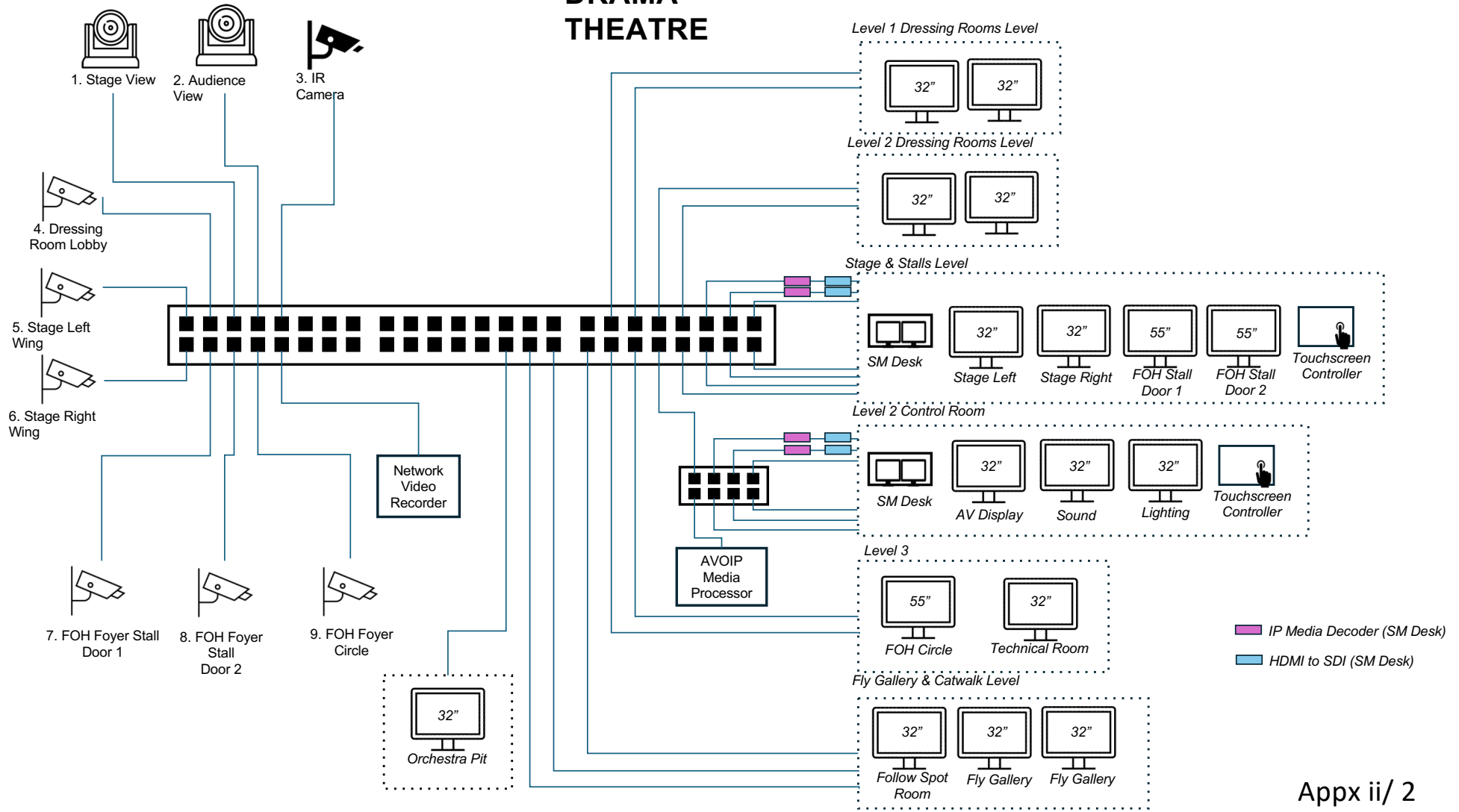

STUDIO THEATRE

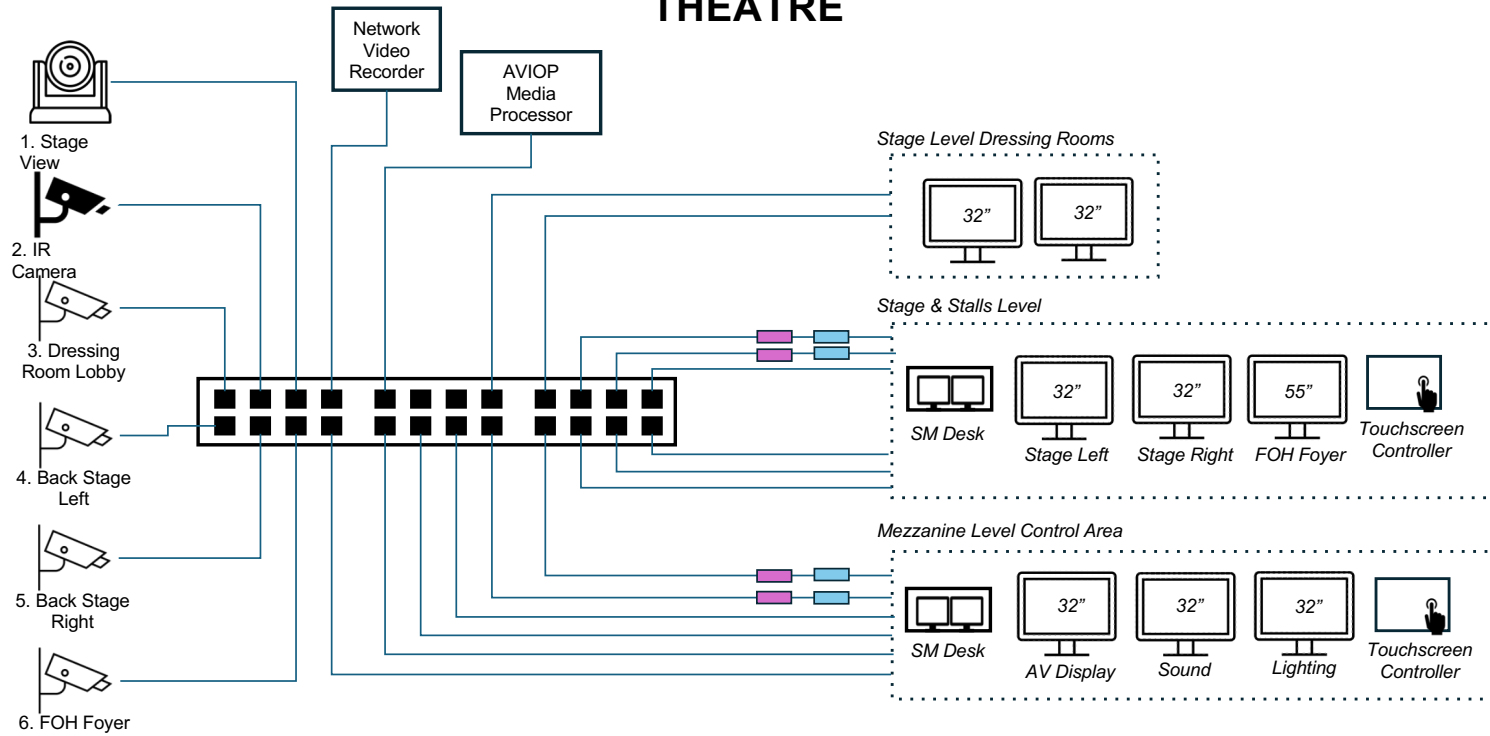

IP Media Decoder (SM Desk)
 HDMI to SDI (SM Desk)

Appendix iii :
TECHNICAL SPECIFICATION FOR
STAGE MANAGER CONTROL DESK

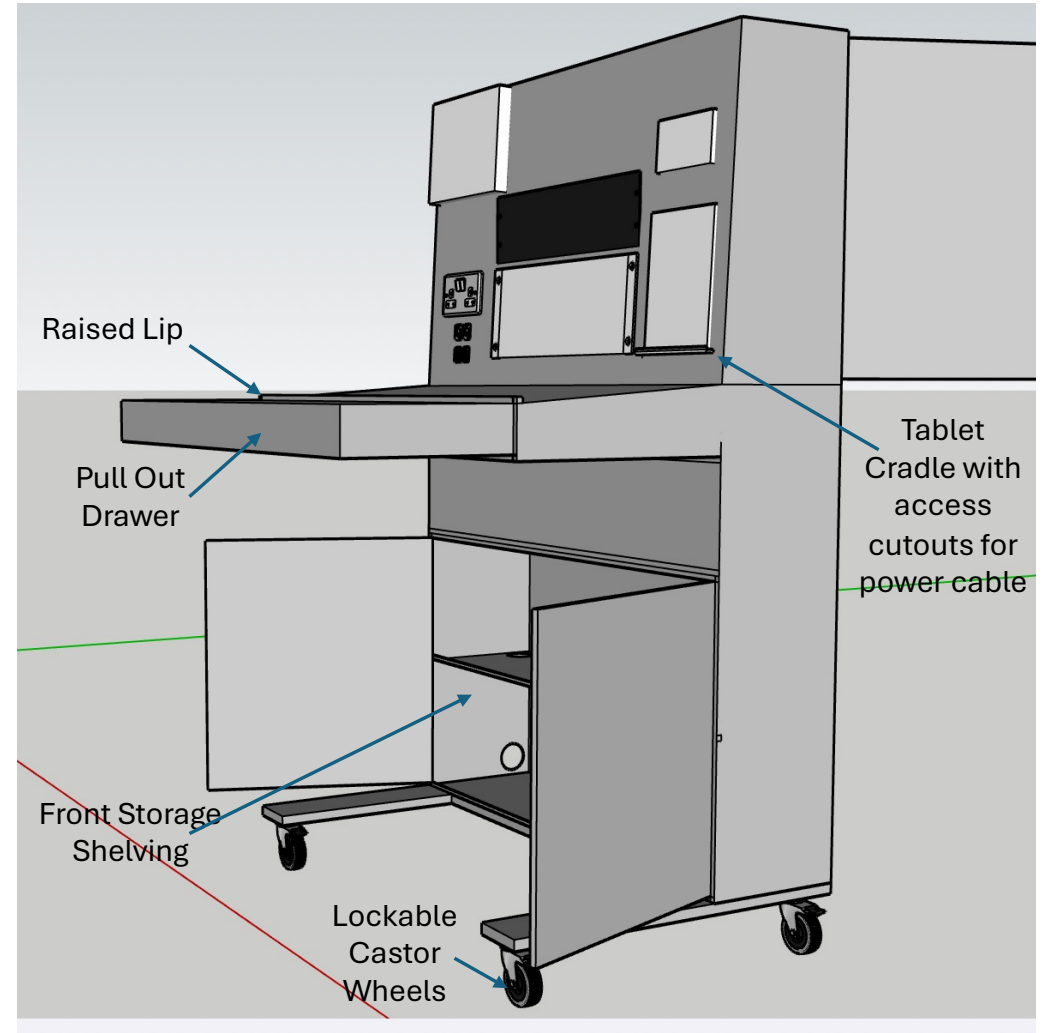
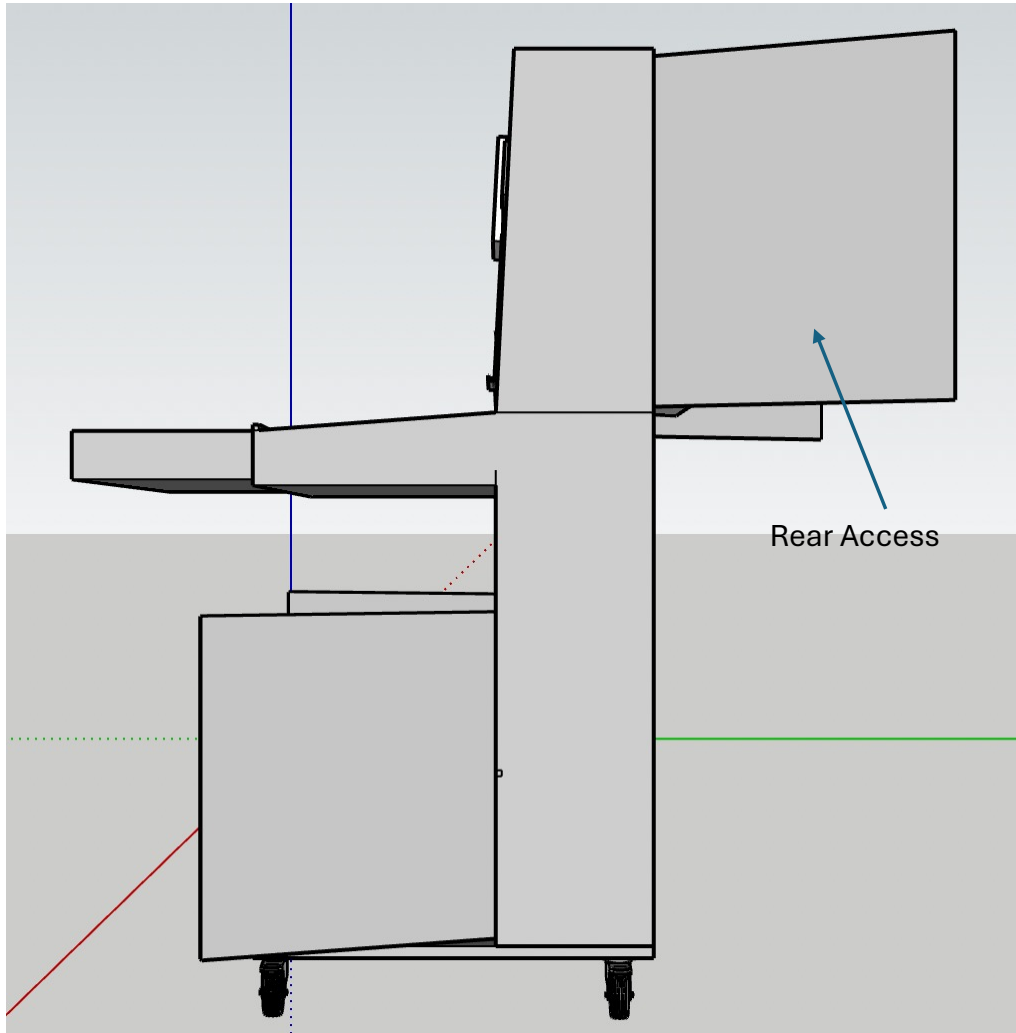

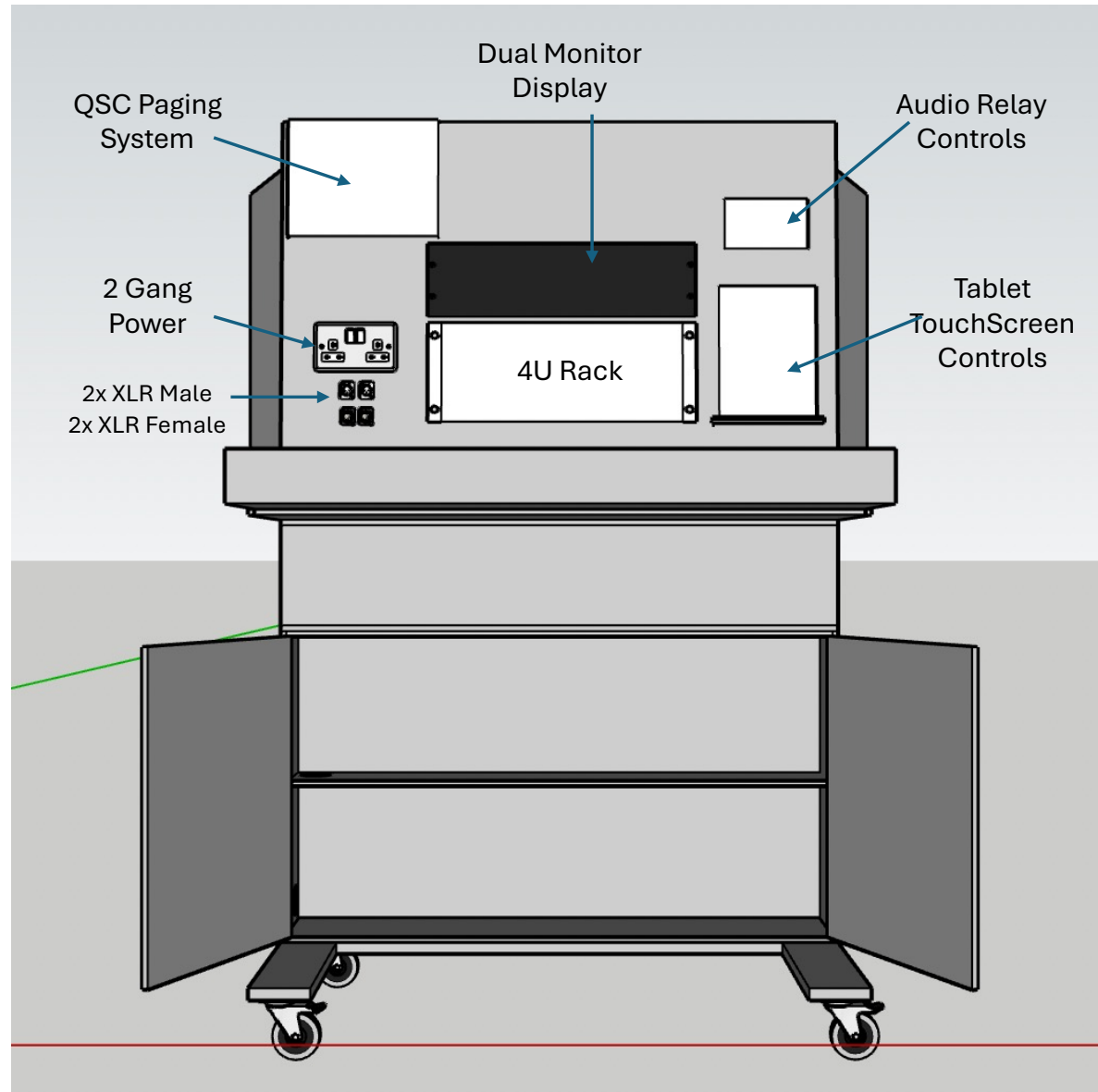

Access Holes
for Cable
Routing

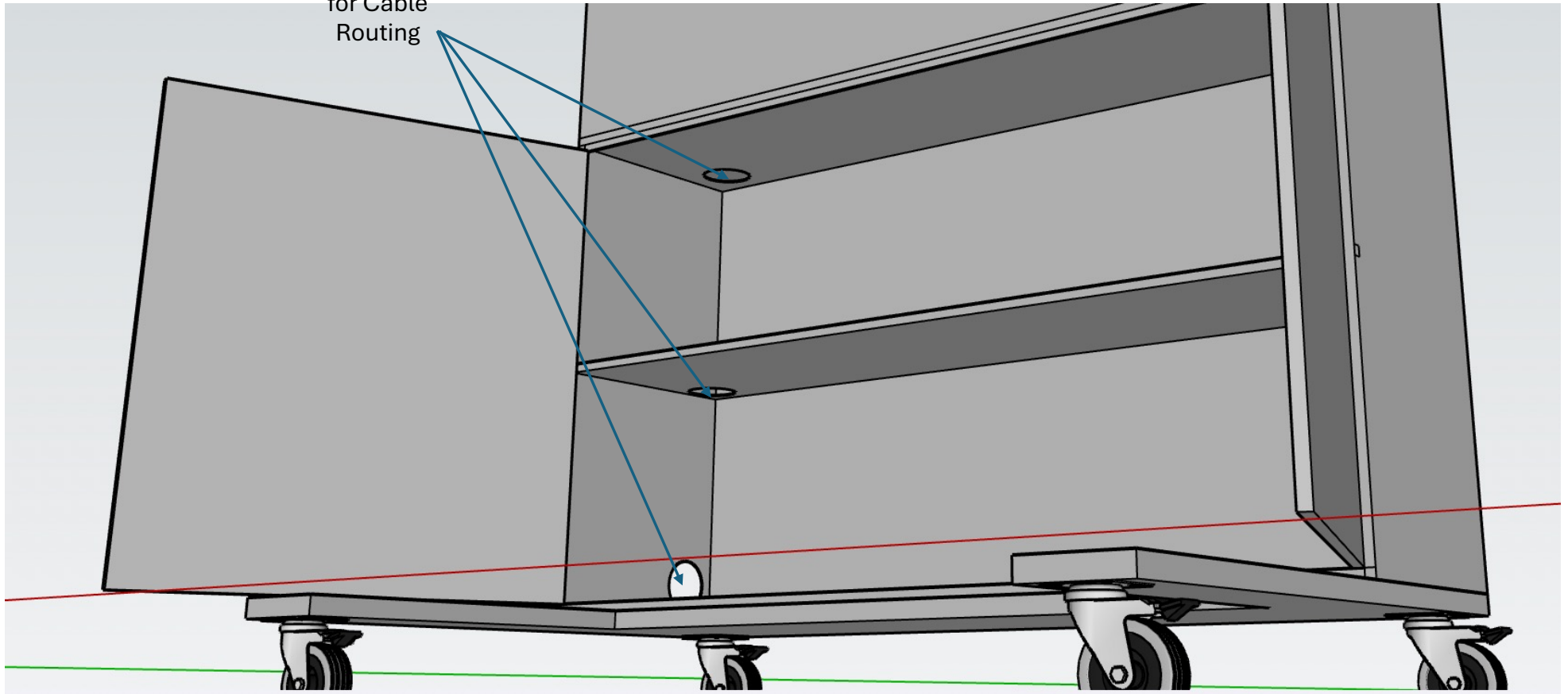

NOTE:
Approximate Dimensions
Shown. Vendor to take
measurements, customize and
build according to safety
guidelines and user
ergonomics

